

SECTION **SRC**

SRS AIRBAG CONTROL SYSTEM

A
B
C
D
E
F
G
SRC
I
J
K
L
M
N
O
P

CONTENTS

<p>PRECAUTION 4</p> <p>PRECAUTIONS 4</p> <p style="padding-left: 20px;">Precaution for Supplemental Restraint System (SRS) "AIR BAG" and "SEAT BELT PRE-TENSIONER"4</p> <p style="padding-left: 20px;">Precaution for SRS "AIR BAG" and "SEAT BELT PRE-TENSIONER" Service4</p> <p>SYSTEM DESCRIPTION 5</p> <p>COMPONENT PARTS 5</p> <p style="padding-left: 20px;">Component Parts Location5</p> <p style="padding-left: 20px;">Component Description6</p> <p style="padding-left: 20px;">Driver Air Bag Module7</p> <p style="padding-left: 20px;">Front Passenger Air Bag Module7</p> <p style="padding-left: 20px;">Side Air Bag Module7</p> <p style="padding-left: 20px;">Side Curtain Air Bag Module7</p> <p style="padding-left: 20px;">Front Seat Belt Pre-tensioner8</p> <p style="padding-left: 20px;">Air Bag Diagnosis Sensor Unit8</p> <p style="padding-left: 20px;">Crash Zone Sensor8</p> <p style="padding-left: 20px;">Front Side Air Bag Satellite Sensor8</p> <p style="padding-left: 20px;">Rear Side Air Bag Satellite Sensor9</p> <p style="padding-left: 20px;">Front Door Satellite Sensor9</p> <p style="padding-left: 20px;">Front Passenger Air Bag Off Indicator9</p> <p style="padding-left: 20px;">SRS Component Connectors9</p> <p>SYSTEM11</p> <p>SRS AIR BAG SYSTEM11</p> <p style="padding-left: 20px;">SRS AIR BAG SYSTEM : System Diagram 11</p> <p style="padding-left: 20px;">SRS AIR BAG SYSTEM : System Description 11</p> <p>OCCUPANT CLASSIFICATION SYSTEM11</p> <p style="padding-left: 20px;">OCCUPANT CLASSIFICATION SYSTEM : System Diagram12</p> <p style="padding-left: 20px;">OCCUPANT CLASSIFICATION SYSTEM : System Description12</p> <p>SEAT BELT WARNING LAMP SYSTEM13</p> <p style="padding-left: 20px;">SEAT BELT WARNING LAMP SYSTEM : System Diagram13</p>	<p style="padding-left: 20px;">SEAT BELT WARNING LAMP SYSTEM : System Description14</p> <p>DIAGNOSIS SYSTEM (AIR BAG)15</p> <p style="padding-left: 20px;">Diagnosis Description15</p> <p style="padding-left: 20px;">SRS Operation Check15</p> <p style="padding-left: 20px;">Trouble Diagnosis with CONSULT16</p> <p style="padding-left: 20px;">SRS History Check16</p> <p style="padding-left: 20px;">SRS Final Check16</p> <p style="padding-left: 20px;">CONSULT Function (AIR BAG)17</p> <p style="padding-left: 20px;">CONSULT Function (OCCUPANT DETECTION)....17</p> <p>ECU DIAGNOSIS INFORMATION18</p> <p>DIAGNOSIS SENSOR UNIT18</p> <p style="padding-left: 20px;">DTC Index18</p> <p>WIRING DIAGRAM23</p> <p>SRS AIR BAG SYSTEM23</p> <p style="padding-left: 20px;">Wiring Diagram23</p> <p>BASIC INSPECTION35</p> <p>DIAGNOSIS AND REPAIR WORK FLOW35</p> <p style="padding-left: 20px;">Work Flow35</p> <p>INSPECTION AND ADJUSTMENT38</p> <p>ADDITIONAL SERVICE WHEN REPLACING CONTROL UNIT38</p> <p style="padding-left: 20px;">ADDITIONAL SERVICE WHEN REPLACING CONTROL UNIT : Description38</p> <p style="padding-left: 20px;">ADDITIONAL SERVICE WHEN REPLACING CONTROL UNIT : Special Repair Requirement38</p> <p>ZERO POINT RESET39</p> <p style="padding-left: 20px;">ZERO POINT RESET : Description39</p> <p style="padding-left: 20px;">ZERO POINT RESET : Special Repair Requirement39</p> <p>CONFIGURATION39</p> <p style="padding-left: 20px;">CONFIGURATION : Work Procedure39</p>
--	---

INTERMITTENT INCIDENT	41	B0097 REAR SIDE AIR BAG SATELLITE	
Inspection Procedure	41	SENSOR RH	81
Trouble Diagnosis with CONSULT	41	DTC Description	81
		Diagnosis Procedure	83
DTC/CIRCUIT DIAGNOSIS	42	B0093 FRONT DOOR SATELLITE SENSOR	
U1000 CAN COMM CIRCUIT	42	LH	86
Description	42	DTC Description	86
DTC Logic	42	Diagnosis Procedure	88
Diagnosis Procedure	42	B0098 FRONT DOOR SATELLITE SENSOR	
U1010 CONTROL UNIT (CAN)	43	RH	90
Description	43	DTC Description	90
DTC Logic	43	Diagnosis Procedure	92
Diagnosis Procedure	43	B00A0 OCCUPANT CLASSIFICATION SYS-	
B0001 DRIVER AIRBAG MODULE	44	TEM CONTROL UNIT	95
DTC Description	44	Description	95
Diagnosis Procedure	45	DTC Description	95
B0010, B0011 PASSENGER AIRBAG MOD-		Diagnosis Procedure (B00A0-00, -02 or -09)	96
ULE	48	Diagnosis Procedure (B00A0-04)	97
DTC Description	48	Diagnosis Procedure (B00A0-83, -86, -87, -88 or -	
Diagnosis Procedure	49	8F)	98
B0020 SIDE AIRBAG MODULE LH	51	Diagnosis Procedure (B00A0-93)	99
DTC Description	51	B00D5 PASSENGER AIR BAG OFF INDICA-	
Diagnosis Procedure	52	TOR	102
B0028 SIDE AIRBAG MODULE RH	54	DTC Description	102
DTC Description	54	Diagnosis Procedure	103
Diagnosis Procedure	55	B1428 SEAT BELT BUCKLE SWITCH LH	105
B0021 SIDE CURTAIN AIR BAG MODULE LH		DTC Description	105
.....	57	Diagnosis Procedure	106
DTC Description	57	B1429 SEAT BELT BUCKLE SWITCH RH	108
Diagnosis Procedure	58	DTC Description	108
B0029 SIDE CURTAIN AIR BAG MODULE		Diagnosis Procedure	109
RH	60	B1430 SEAT BELT PRE-TENSIONER	111
DTC Description	60	DTC Description	111
Diagnosis Procedure	61	Diagnosis Procedure	112
B0094 CRASH ZONE SENSOR	63	B1431 SEAT BELT PRE-TENSIONER	114
DTC Description	63	DTC Description	114
Diagnosis Procedure	64	Diagnosis Procedure	115
B0091 FRONT SIDE AIR BAG SATELLITE		B1432 LAP PRE-TENSIONER	117
SENSOR LH	67	DTC Logic	117
DTC Description	67	Diagnosis Procedure	118
Diagnosis Procedure	69	B1433 LAP PRE-TENSIONER	120
B0096 FRONT SIDE AIR BAG SATELLITE		DTC Description	120
SENSOR RH	72	Diagnosis Procedure	121
DTC Description	72	B1436 ACTIVE VENT	123
Diagnosis Procedure	75	DTC Description	123
B0092 REAR SIDE AIR BAG SATELLITE		Diagnosis Procedure	124
SENSOR LH	77	B142A IGNITION VOLTAGE	126
DTC Description	77	DTC Description	126
Diagnosis Procedure	79	Diagnosis Procedure	127

B1427 CONFIG SETTING	129	B14XX AIR BAG DIAGNOSIS SENSOR UNIT.	140
DTC Description	129	DTC Description	140
Diagnosis Procedure	129	Diagnosis Procedure	141
B1400, B1401, B1402, B1403, B1404, B1405		SYMPTOM DIAGNOSIS	142
AIR BAG DIAGNOSIS SENSOR UNIT	130	SRS AIR BAG WARNING LAMP DOES NOT	
DTC Description	130	TURN ON	142
Diagnosis Procedure	131	Air Bag Warning Lamp Does Not Turn On	142
B1406, B1407, B1408, B1409, B1410 AIR		SRS AIR BAG WARNING LAMP DOES NOT	
BAG DIAGNOSIS SENSOR UNIT	132	TURN OFF	143
DTC Description	132	Air Bag Warning Lamp Does Not Turn Off	143
Diagnosis Procedure	133	SEAT BELT WARNING SYSTEM	144
B1411, B1412, B1413, B1414, B1415 AIR		Seat Belt Warning System Does Not Function	144
BAG DIAGNOSIS SENSOR UNIT	134	A/B WARNING LAMP IS OFF, PASS A/B IN-	
DTC Description	134	DCTR LAMP TURNS ON INTERMIT	145
Diagnosis Procedure	134	Description	145
B1416, B1417, B1418, B1419, B1420 AIR		Diagnosis Procedure	145
BAG DIAGNOSIS SENSOR UNIT	136	SEAT BELT INDCTR LAMP IS ON, PASS AIR	
DTC Description	136	BAG INDCTR IS ON OR OFF	146
Diagnosis Procedure	137	Description	146
B142X COLLISION DETECTION	138	Diagnosis Procedure	146
DTC Description	138		
Diagnosis Procedure	139		

A
B
C
D
E
F
G
I
J
K
L
M
N
O
P

SRC

PRECAUTIONS

< PRECAUTION >

PRECAUTION

PRECAUTIONS

Precaution for Supplemental Restraint System (SRS) "AIR BAG" and "SEAT BELT PRE-TENSIONER"

INFOID:000000012271653

The Supplemental Restraint System such as "AIR BAG" and "SEAT BELT PRE-TENSIONER", used along with a front seat belt, helps to reduce the risk or severity of injury to the driver and front passenger for certain types of collision. Information necessary to service the system safely is included in the SR and SB section of this Service Manual.

WARNING:

- To avoid rendering the SRS inoperative, which could increase the risk of personal injury or death in the event of a collision which would result in air bag inflation, it is recommended that all maintenance and repair be performed by an authorized NISSAN/INFINITI dealer.
- Improper repair, including incorrect removal and installation of the SRS, can lead to personal injury caused by unintentional activation of the system. For removal of Spiral Cable and Air Bag Module, see the SR section.
- Do not use electrical test equipment on any circuit related to the SRS unless instructed to in this Service Manual. SRS wiring harnesses can be identified by yellow and/or orange harnesses or harness connectors.

PRECAUTIONS WHEN USING POWER TOOLS (AIR OR ELECTRIC) AND HAMMERS

WARNING:

- When working near the Air Bag Diagnosis Sensor Unit or other Air Bag System sensors with the Ignition ON or engine running, DO NOT use air or electric power tools or strike near the sensor(s) with a hammer. Heavy vibration could activate the sensor(s) and deploy the air bag(s), possibly causing serious injury.
- When using air or electric power tools or hammers, always switch the Ignition OFF, disconnect the battery or batteries, and wait at least three minutes before performing any service.

Precaution for SRS "AIR BAG" and "SEAT BELT PRE-TENSIONER" Service

INFOID:000000012159625

- Do not use electrical test equipment to check SRS circuits unless instructed to in this Service Manual.
- Before servicing the SRS, turn ignition switch OFF, disconnect both battery cables and wait at least 3 minutes.
For approximately 3 minutes after the cables are removed, it is still possible for the air bag and seat belt pretensioner to deploy. Therefore, do not work on any SRS connectors or wires until at least 3 minutes have passed.
- The air bag diagnosis sensor unit must always be installed with the arrow mark "←" pointing toward the front of the vehicle for proper operation. Also check air bag diagnosis sensor unit for cracks, deformities or rust before installation and replace as required.
- The spiral cable must be aligned with the neutral position since its rotations are limited. Do not attempt to turn steering wheel or column after removal of steering gear.
- Handle air bag module carefully. Always place driver and front passenger air bag modules with the pad side facing upward and seat mounted front side air bag module standing with the stud bolt side facing down.
- Conduct self-diagnosis to check entire SRS for proper function after replacing any components.
- After air bag inflates, the front instrument panel assembly should be replaced if damaged.

COMPONENT PARTS

< SYSTEM DESCRIPTION >

SYSTEM DESCRIPTION

COMPONENT PARTS

Component Parts Location

INFOID:000000012159626

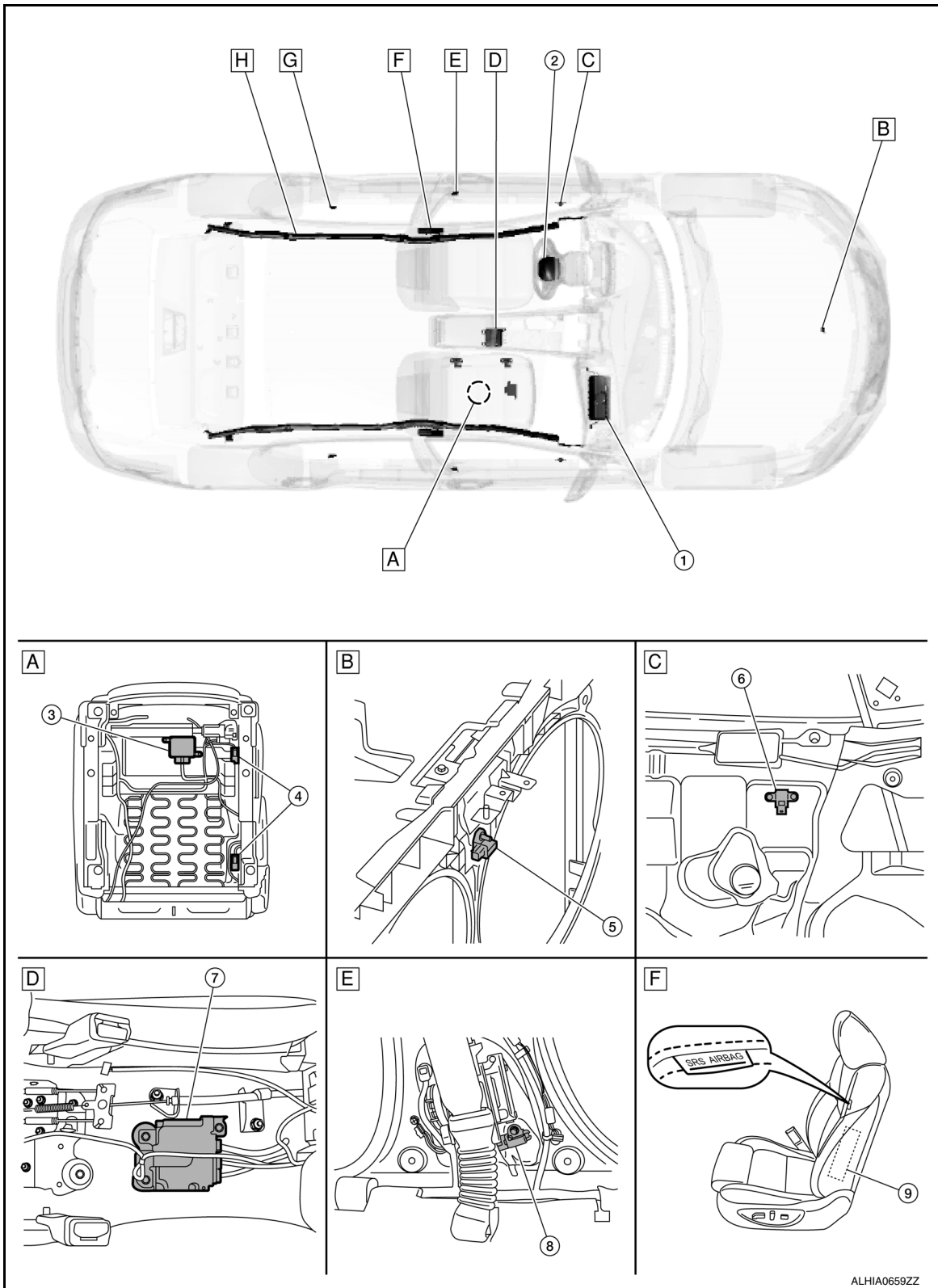

A

B

C

D

E

F

G

SRC

I

J

K

L

M

N

O

P

ALHIA0659ZZ

COMPONENT PARTS

< SYSTEM DESCRIPTION >

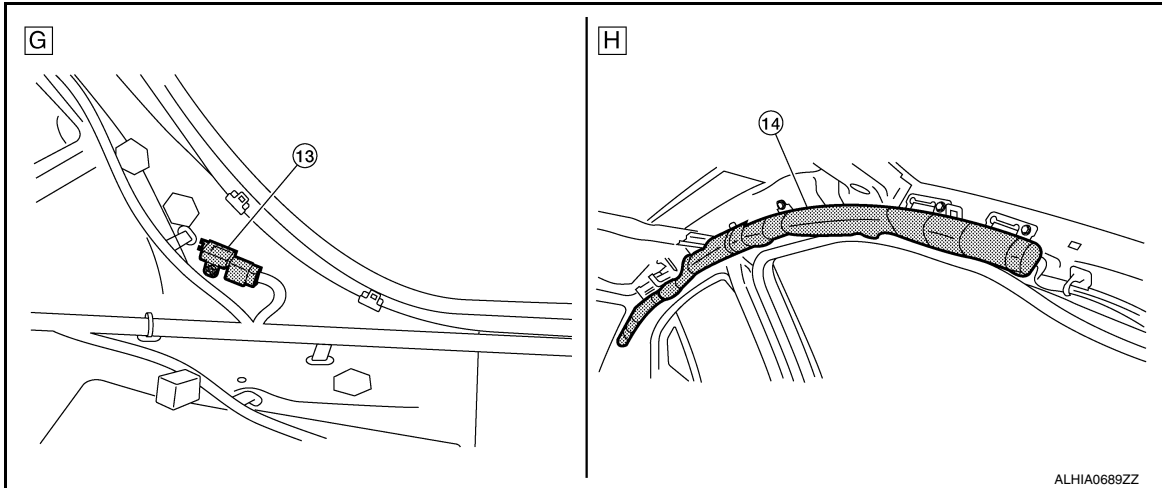

- A. Bottom of passenger seat (view with passenger seat removed)
- B. Front of engine compartment
- C. Driver door area (view with front door finisher LH removed)
- D. Between driver and passenger seat (view with center console removed)
- E. Left of passenger seat (view with center pillar lower finisher removed)
- F. Driver seat area
- G. Left of rear passenger seat (view with rear kicking plate inner LH removed)
- H. Left side of roof line (view with headliner and front pillar finisher removed)

Component Description

INFOID:000000012159627

No.	Component	Function
1.	Front passenger air bag module	Refer to SRC-7, "Front Passenger Air Bag Module" .
2.	Driver air bag module	Refer to SRC-7, "Driver Air Bag Module" .
3.	Occupant classification system control unit	Refer to SRC-12, "OCCUPANT CLASSIFICATION SYSTEM : System Description" .
4.	Occupant classification sensors	Refer to SRC-12, "OCCUPANT CLASSIFICATION SYSTEM : System Description" .
5.	Crash zone sensor	Refer to SRC-8, "Crash Zone Sensor" .
6.	Front door satellite sensor LH	Refer to SRC-9, "Front Door Satellite Sensor" .
7.	Air bag diagnosis sensor unit	Refer to SRC-8, "Air Bag Diagnosis Sensor Unit" .
8.	Front side air bag (satellite) sensor LH	Refer to SRC-8, "Front Side Air Bag Satellite Sensor" .
9.	Front LH side air bag module LH	Refer to SRC-7, "Front Passenger Air Bag Module" .
10.	Rear side air bag satellite sensor LH	Refer to SRC-9, "Rear Side Air Bag Satellite Sensor" .
11.	LH side curtain air bag module	Refer to SRC-7, "Side Curtain Air Bag Module" .

COMPONENT PARTS

< SYSTEM DESCRIPTION >

Driver Air Bag Module

INFOID:000000012159628

The driver air bag module is single stage and located in the steering wheel assembly. It operates with the SRS system in a frontal collision exceeding a specified level.

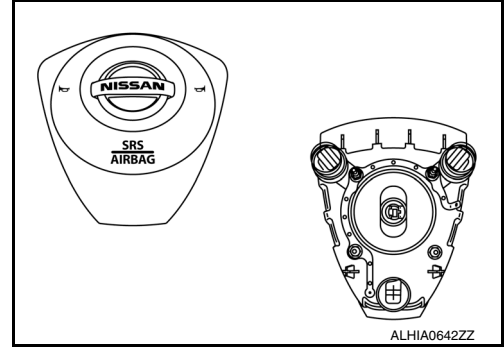

Front Passenger Air Bag Module

INFOID:000000012159629

The front passenger air bag module is dual stage and is located behind the instrument panel assembly. It operates with the SRS system in a frontal collision exceeding a specified level. Refer to [SRC-11, "SRS AIR BAG SYSTEM : System Description"](#) for more information.

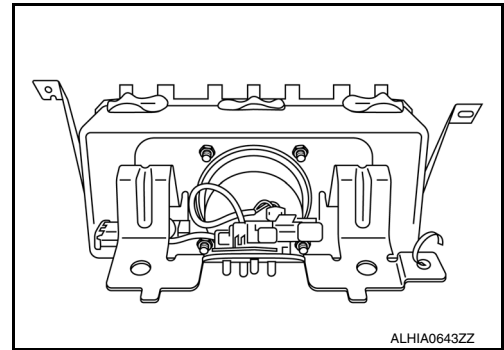

Side Air Bag Module

INFOID:000000012159631

Side air bag modules are built into the front seatback assemblies. Vehicles with side air bags are equipped with labels as shown.

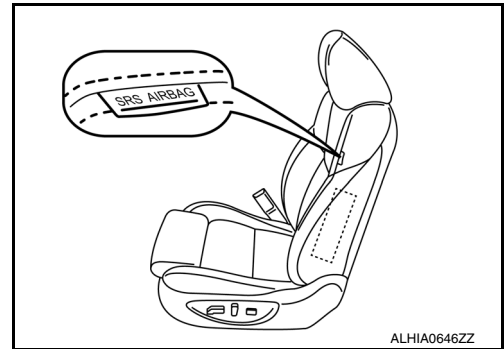

Side Curtain Air Bag Module

INFOID:000000012159632

Side curtain air bag modules are located above the vehicle headlining. Vehicles with side curtain air bags are equipped with labels on the pillar upper finishers.

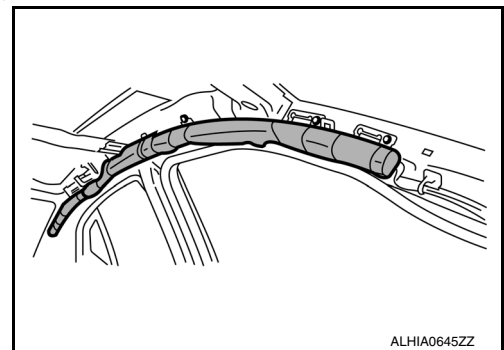

A
B
C
D
E
F
G
I
J
K
L
M
N
O
P

SRC

COMPONENT PARTS

< SYSTEM DESCRIPTION >

Front Seat Belt Pre-tensioner

INFOID:000000012159633

The seat belt pre-tensioner system with load limiter is installed for both the driver seat and the front passenger seat. It operates simultaneously with the SRS air bag system in the event of a frontal collision with an impact exceeding a specified level.

When a frontal collision with an impact exceeding a specified level occurs, seat belt slack resulting from clothing or other factors is immediately taken up by the shoulder belt pre-tensioner (1) as well as the passenger seat lap belt pre-tensioner (2). Vehicle passengers are securely restrained.

When passengers in a vehicle are thrown forward in a collision and the restraining force of the seat belt exceeds a specified level, the load limiter permits the specified extension of the seat belt by the twisting of the ELR shaft and a relaxation of the chest-area seat belt web tension while maintaining force.

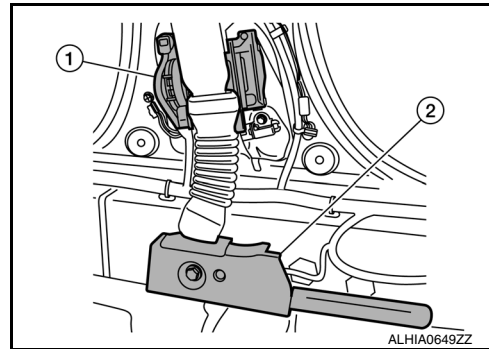

Air Bag Diagnosis Sensor Unit

INFOID:000000012159634

The air bag diagnosis sensor unit is located under the center console assembly. The air bag diagnosis sensor unit receives signals from multiple SRS sensors and controls the deployment of the air bags. The deployment of the air bags depends on the type and severity of the collision. The air bag diagnosis sensor unit has self-diagnosis capability through the use of the CONSULT as well as flash codes displayed by the air bag warning lamp.

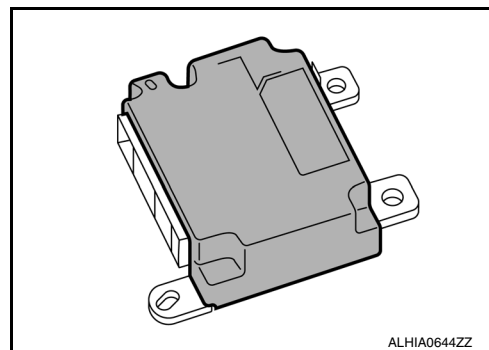

Crash Zone Sensor

INFOID:000000012159635

The crash zone sensor is located behind the radiator attached to the hood release bracket. The crash zone sensor sends signals to the air bag diagnosis sensor unit during a frontal collision. This sensor may be identified by a yellow connector.

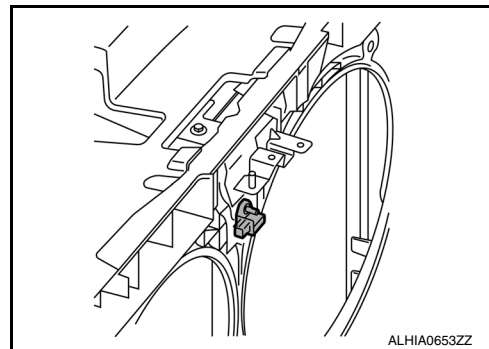

Front Side Air Bag Satellite Sensor

INFOID:000000012159636

The front side air bag satellite sensors are located on the front center pillar LH and RH next to the seat belt pre-tensioners. The front side air bag satellite sensors send signals to the air bag diagnosis sensor unit during a side collision. These sensors may be identified by yellow connectors.

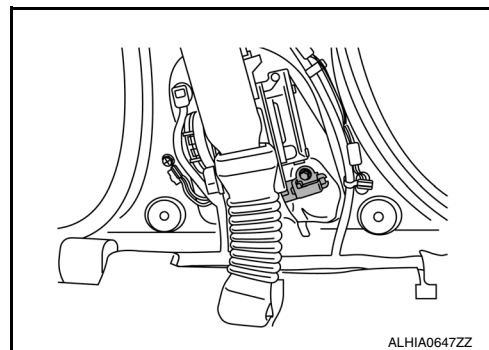

COMPONENT PARTS

< SYSTEM DESCRIPTION >

Rear Side Air Bag Satellite Sensor

INFOID:000000012159637

The rear side air bag satellite sensors are located behind the rear wheel house finisher LH and RH. The rear side air bag satellite sensors send signals to the air bag diagnosis sensor unit during a side collision. These sensors may be identified by yellow connectors.

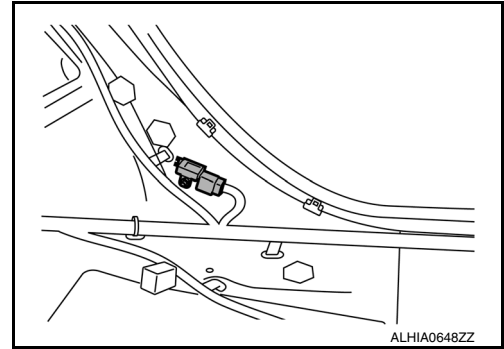

Front Door Satellite Sensor

INFOID:000000012159638

The front door satellite sensors are located in the driver and passenger doors. The front door satellite sensors send signals to the air bag diagnosis sensor unit during a side collision. These sensors may be identified by yellow connectors.

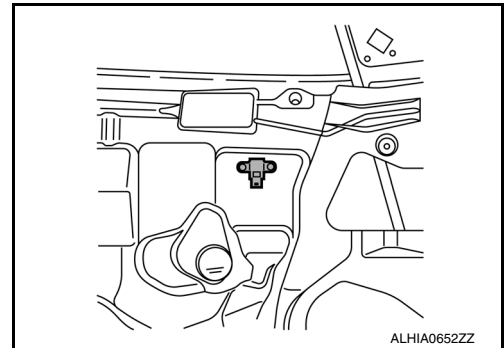

Front Passenger Air Bag Off Indicator

INFOID:000000012159639

Front passenger air bag OFF indicator indicates whether or not passenger air bag is in the activation mode based on the judgment of occupant detection system.



SRS Component Connectors

INFOID:000000012159640

DIRECT CONNECT

The following SRS components use direct-connect style harness connectors:

- Driver front air bag module
- Passenger front air bag module
- LH side curtain air bag module
- RH side curtain air bag module
- Front LH seat belt pre-tensioner
- Front RH seat belt pre-tensioner

Always pull up to release locking tab prior to removing connector from SRS component.

A
B
C
D
E
F
G
SRC
I
J
K
L
M
N
O
P

COMPONENT PARTS

< SYSTEM DESCRIPTION >

Always push down to lock locking tab after installing connector to SRS component. When locked, the locking tab is level with the connector housing.

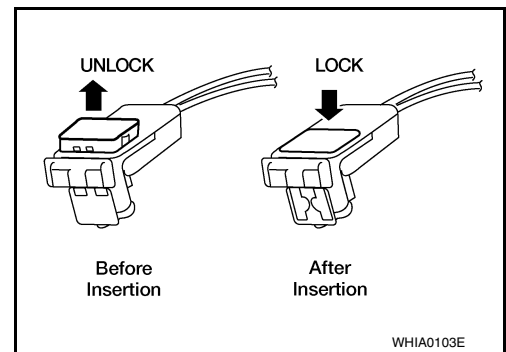

SLIDE DOUBLE LOCKING

- A new style slide double locking type connector is used on certain systems and components especially those related to air bag control systems.
- The slide double locking type connectors help prevent incomplete locking and accidental looseness or disconnection.
- The slide double locking type connectors are disconnected by pushing or pulling the slider. Refer to the figure below.

CAUTION:

- **Do not pull the harness or wires when disconnecting the connector.**

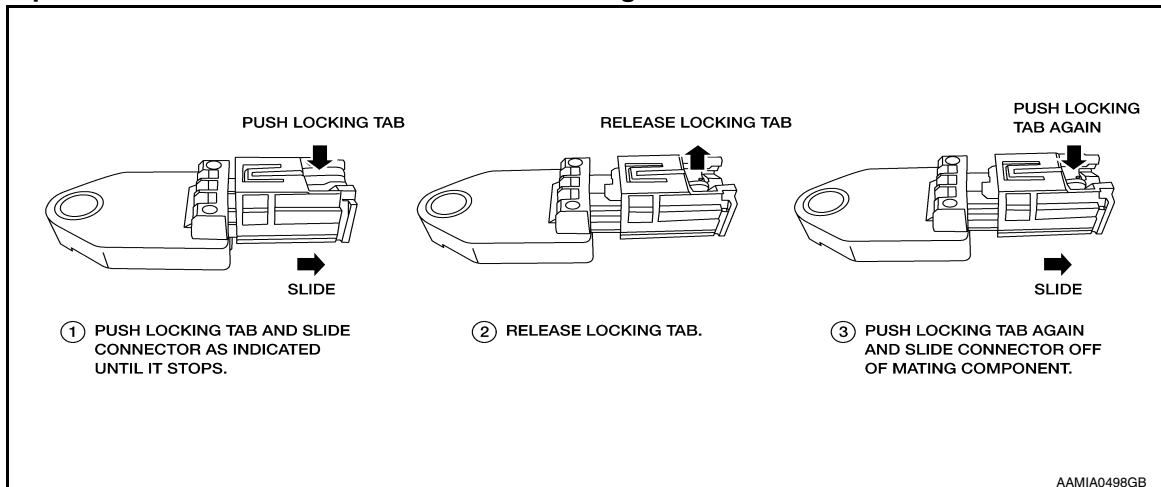

SYSTEM

< SYSTEM DESCRIPTION >

SYSTEM

SRS AIR BAG SYSTEM

SRS AIR BAG SYSTEM : System Diagram

INFOID:000000012159641

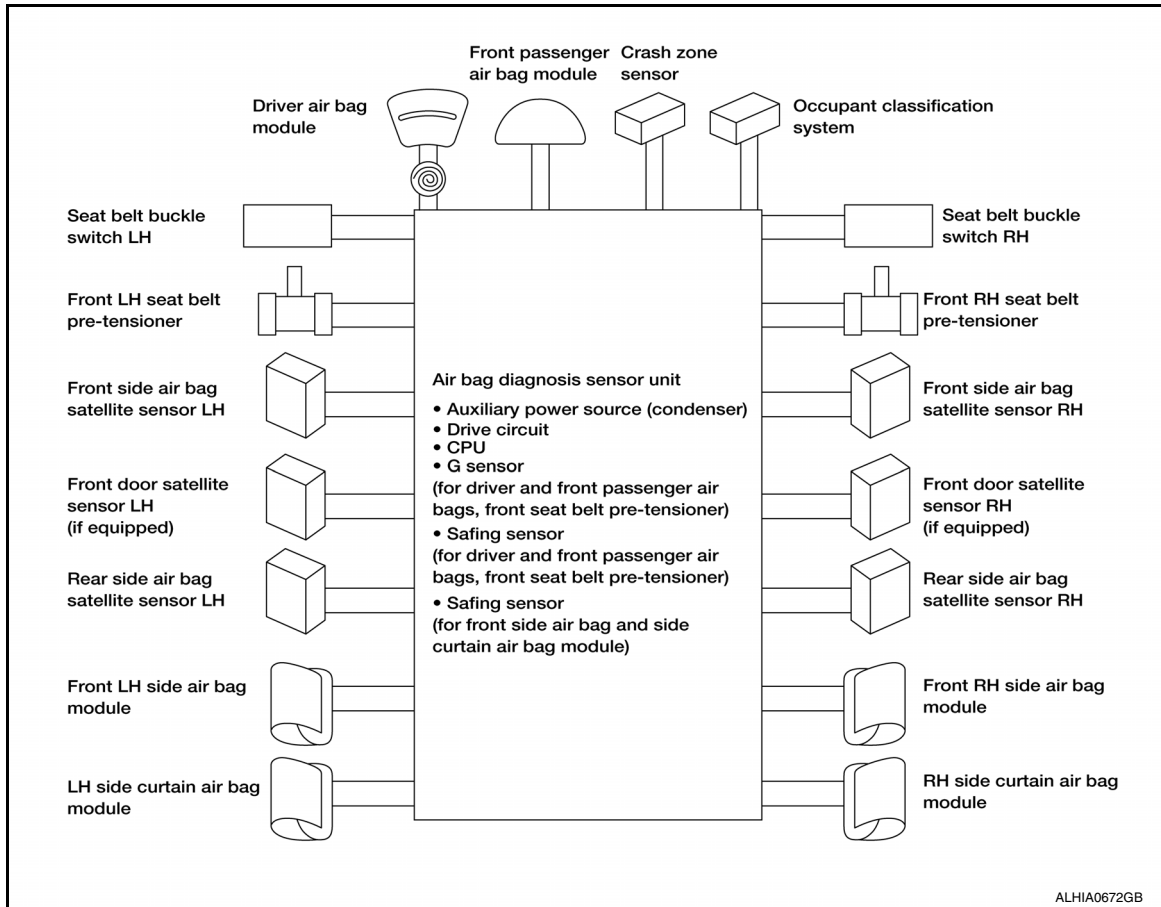

ALHIA0672GB

SRS AIR BAG SYSTEM : System Description

INFOID:000000012159642

- The air bag deploys if the air bag diagnosis sensor unit is activated while the ignition switch is in the ON or START position.
- The collision modes for which supplemental restraint systems are activated are different among the SRS systems. For example, the driver air bag module, front passenger air bag module and front seat belt pre-tensioner are activated in a frontal collision but not in a side collision.

SRS Collision Modes

SRS configuration	Frontal collision	Left side collision	Right side collision	Rollover
Driver air bag module	x	—	—	—
Front passenger air bag module	x	—	—	—
Front LH seat belt pre-tensioner	x	—	—	x
Front RH seat belt pre-tensioner	x	—	—	x
Side air bag module LH	—	x	—	—
Side air bag module RH	—	—	x	—
LH side curtain air bag module	—	x	—	x
RH side curtain air bag module	—	—	x	x

OCCUPANT CLASSIFICATION SYSTEM

A

B

C

D

E

F

G

SRC

I

J

K

L

M

N

O

P

SYSTEM

< SYSTEM DESCRIPTION >

OCCUPANT CLASSIFICATION SYSTEM : System Diagram

INFOID:000000012159643

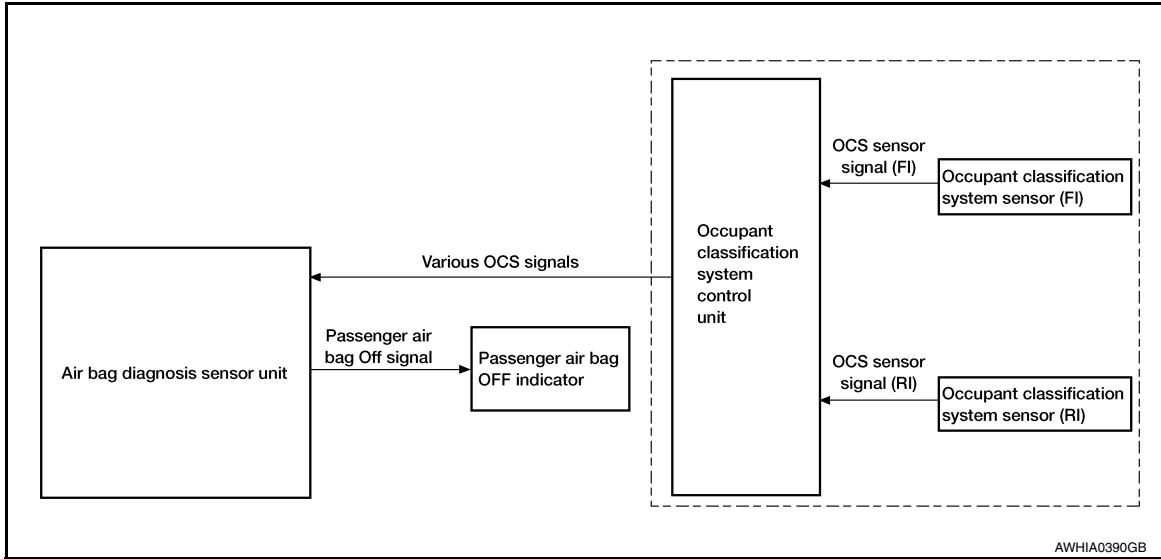

OCCUPANT CLASSIFICATION SYSTEM : System Description

INFOID:000000012159644

The occupant classification system (OCS) identifies different size occupants, out of position occupants, and detects if a child seat is present in the front passenger seat. The OCS control unit (1) receives inputs from the occupant classification sensors (2) (located inside the passenger seat cushion assembly). Depending on classification of the passenger, the OCS sends a signal to the air bag diagnosis sensor unit. The air bag diagnosis sensor unit uses this signal and the seat belt buckle switch RH signal to determine deployment or non-deployment of the passenger front air bag in the event of a collision. Depending on the signals received, the air bag diagnosis sensor unit can disable the passenger front air bag completely. The OCS (weight sensors) must be set to zero point using CONSULT after servicing the OCS system.

NOTE:

- CONSULT can be used to confirm when “zero point reset” for OCS is complete.
- Always perform zero point reset after the removal and installation of the seat or when disconnecting the OCS control unit harness connector even if zero point reset has been completed in the past.
- If zero point reset is incomplete, the passenger air bag will be disabled and the passenger air bag off indicator will be ON.
- In case of customer concern, CONSULT can be used to confirm the passenger air bag status (readiness).

Passenger Air Bag Status Conditions

Front Passenger Seat (Condition)	PASS AIR BAG OFF Indicator (Status)	Passenger Air Bag Status (Readiness)	CONSULT Display
Seat occupied	OFF	Active (enabled)	ON
Seat occupied ^{NOTE}	ON	Deactivated (disabled)	OFF
Seat empty	OFF	Deactivated (disabled)	OFF

NOTE:

Passenger does not meet Occupant Classification System specifications for passenger air bag activation.

SYSTEM

< SYSTEM DESCRIPTION >

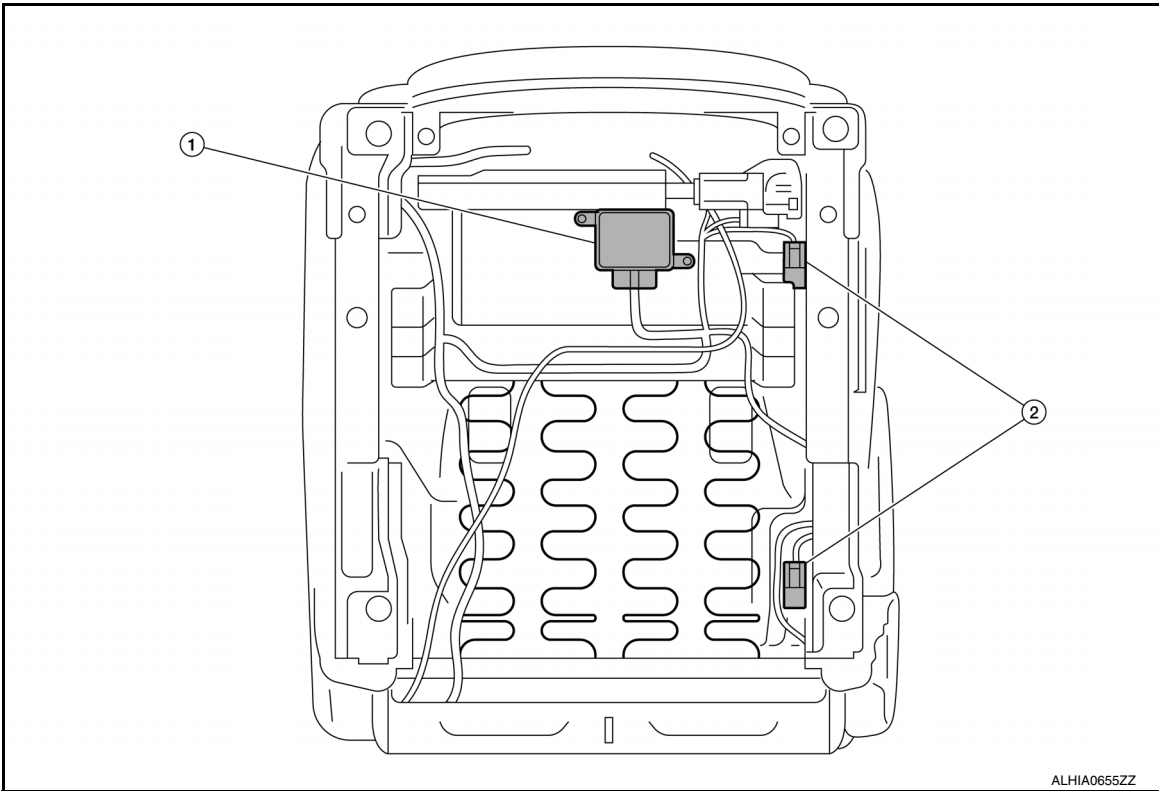

SEAT BELT WARNING LAMP SYSTEM

SEAT BELT WARNING LAMP SYSTEM : System Diagram

INFOID:000000012159645

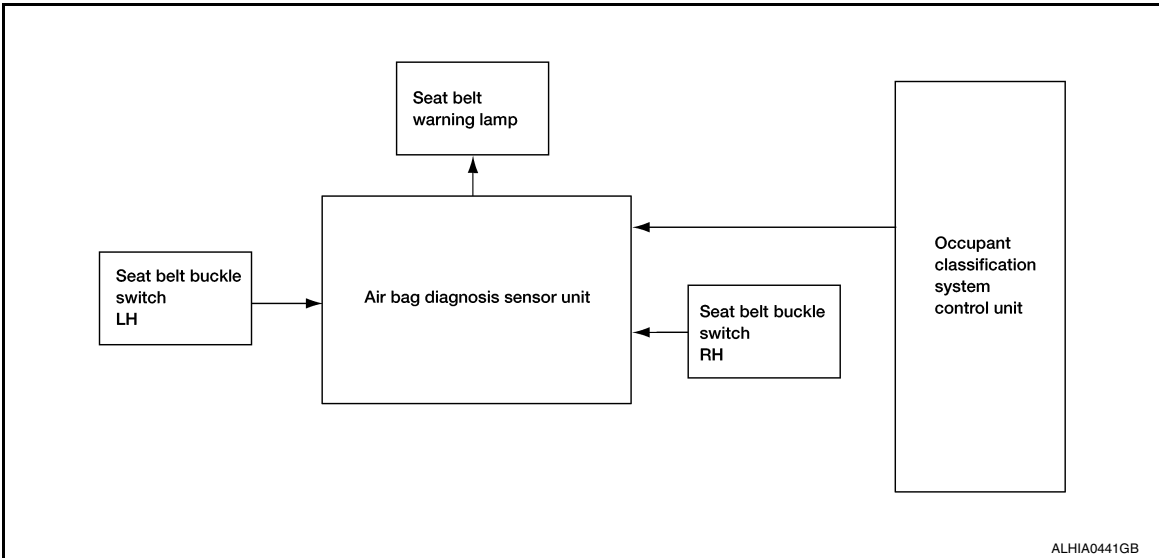

SYSTEM

< SYSTEM DESCRIPTION >

SEAT BELT WARNING LAMP SYSTEM : System Description

INFOID:000000012159646

The seat belt warning lamp (1) will remind the driver if the driver or front passenger seat belt should be buckled. The system works in conjunction with the occupant classification system. Refer to [SRC-12. "OCCUPANT CLASSIFICATION SYSTEM : System Description"](#).

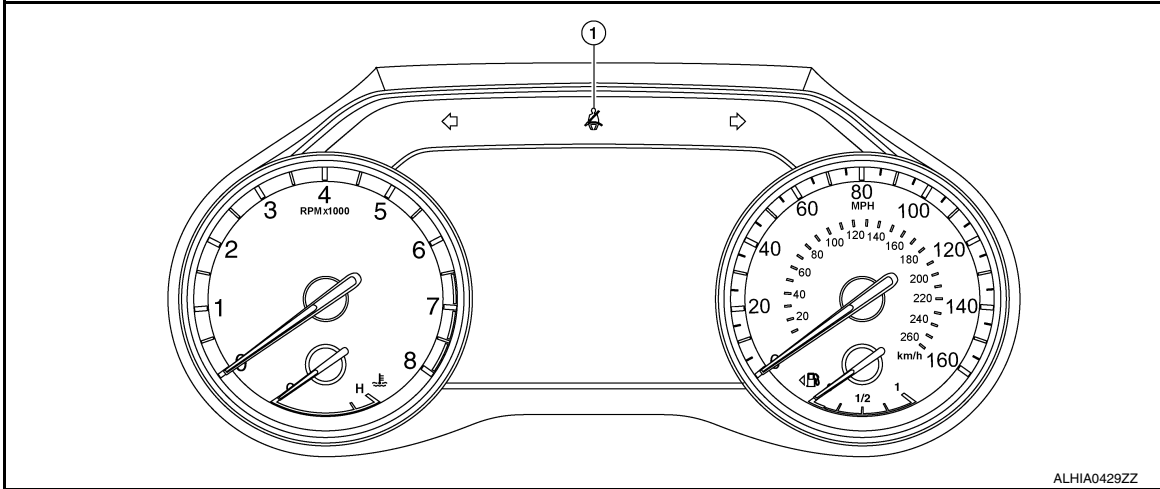

Seat Belt Warning System Operation

Driver seat status (ignition switch ON)	Passenger seat status	Seat belt buckle switch LH status	Seat belt buckle switch RH status	Seat belt warning lamp
Seat occupied	Seat occupied	Buckled	Buckled	Off
			Unbuckled	On
	Seat unoccupied	Unbuckled	—	Off
			—	On

DIAGNOSIS SYSTEM (AIR BAG)

< SYSTEM DESCRIPTION >

DIAGNOSIS SYSTEM (AIR BAG)

Diagnosis Description

INFOID:000000012159647

CAUTION:

- Do not use electrical test equipment on any circuit related to the SRS unless instructed to do so in this Service Manual. SRS wiring harnesses can be identified by yellow and/or orange harness connectors.
- Do not attempt to repair, splice or modify SRS wiring harnesses. If a harness is damaged, replace it with a new one.
- Keep ground connections clean.

HOW TO PERFORM TROUBLE DIAGNOSES FOR QUICK AND ACCURATE REPAIR

1. Obtain information about the symptom.
 - WHAT - vehicle model
 - WHEN - date, frequencies
 - WHERE - road conditions
 - HOW - operating conditions, symptoms, passengers
2. Perform Preliminary Check.
 - Battery
 - Fuses
 - Harness connections

DIAGNOSIS METHODS

SRS "Self Diagnostic Result" can be read by using the AIR BAG warning lamp or CONSULT.

The User Mode is for the customer (driver). This mode warns the driver of a system malfunction through the AIR BAG warning lamp.

The Diagnosis Mode is for the technician. This mode helps the technician locate the malfunctioning circuit or part.

	User Mode	Diagnosis Mode	Display type
AIR BAG warning lamp	X	X	ON/OFF
CONSULT	—	X	Monitoring

SRS Operation Check

INFOID:000000012159648

USER MODE

1. Turn the ignition switch from OFF to ON and check that the air bag warning lamp blinks.
2. Compare the blinking pattern with the examples in the table.



DIAGNOSIS SYSTEM (AIR BAG)

< SYSTEM DESCRIPTION >

Air bag warning lamp flashing pattern (User Mode)

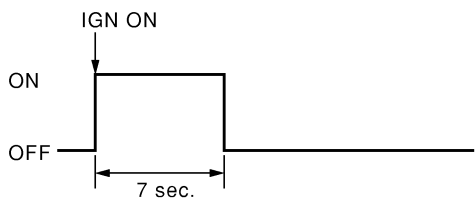
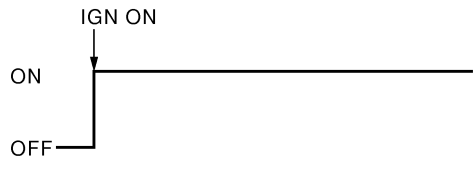
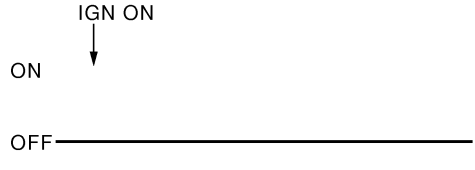
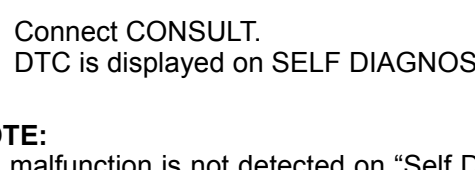
Warning lamp	SRS condition	Reference item
 <p>SHIA0011E</p>	<ul style="list-style-type: none"> No malfunction is detected. No further action is necessary. 	—
 <p>SHIA0013E</p>	<ul style="list-style-type: none"> Air bag is deployed. Seat belt pre-tensioner is deployed. 	Refer to SR-5, "For Frontal Collision" or SR-7, "For Side and Rollover Collision" .
 <p>SHIA0014E</p>	<ul style="list-style-type: none"> Air bag diagnosis sensor unit is malfunctioning. Air bag power supply circuit is malfunctioning. SRS air bag warning lamp circuit is malfunctioning. 	Refer to SRC-143, "Air Bag Warning Lamp Does Not Turn Off" .
 <p>SHIA0014E</p>	<ul style="list-style-type: none"> Air bag diagnosis sensor unit is malfunctioning. Air bag warning lamp circuit is malfunctioning. 	Refer to SRC-142, "Air Bag Warning Lamp Does Not Turn On" .

Trouble Diagnosis with CONSULT

INFOID:0000000012159649

1. Connect CONSULT.
2. DTC is displayed on SELF DIAGNOSTIC RESULT.

NOTE:

If a malfunction is not detected on "Self Diagnostic Result [CURRENT]", but a malfunction is detected during SRS Operation Check, the following cases may exist:

- "Self Diagnostic Result [PAST]" memory might not be erased. Refer to [SRC-16, "SRS Final Check"](#).
- SRS system malfunctions intermittently. Refer to [SRC-41, "Inspection Procedure"](#).

SRS History Check

INFOID:0000000012159650

SRS HISTORY CHECK

1. Check repair history of the SRS. If no repairs have been made, perform [SRC-15, "SRS Operation Check"](#). If repairs have been made, GO TO step 2.
2. Erase "Self Diagnostic Result [PAST]" after repair. Refer to [SRC-16, "SRS Final Check"](#).

SRS Final Check

INFOID:0000000012159651

DIAGNOSIS MODE

1. Connect CONSULT.

DIAGNOSIS SYSTEM (AIR BAG)

< SYSTEM DESCRIPTION >

2. Confirm that zero point reset of OCS is complete.
3. If no DTCs are detected on "Self Diagnostic Result [CURRENT]", repair of SRS is completed. Go to step 4.
If any DTCs are detected on "Self Diagnostic Result [CURRENT]", the malfunction has not been repaired completely or another malfunction is being detected. Perform SRS Operation Check again. Refer to [SRC-15. "SRS Operation Check"](#).
4. Touch "ERASE".
NOTE:
Touching "ERASE" will clear the SRS memory of the malfunction ("Self Diagnostic Result [PAST]"). If "Self Diagnostic Result [PAST]" is not erased, User Mode may show the previous system malfunction even if the malfunction has been repaired completely.
5. Check that no malfunction is detected in "Self Diagnostic Result [PAST]".
6. Exit Diagnosis Mode and disconnect the CONSULT.
7. Perform SRS Operation Check. Refer to [SRC-15. "SRS Operation Check"](#).

CONSULT Function (AIR BAG)

INFOID:000000012159652

CAUTION:

After disconnecting the CONSULT vehicle interface (VI) from the data link connector, the ignition must be cycled OFF → ON (for at least 5 seconds) → OFF. If this step is not performed, the BCM may not go to "sleep mode", potentially causing a discharged battery and no-start condition.

APPLICATION ITEMS

CONSULT can display each diagnostic item using the diagnostic test modes shown following:

Diagnostic Test Mode	Diagnostic Item	Description
"Self Diagnostic Result"	SELF DIAGNOSTIC RESULT [CURRENT]	A current "Self Diagnostic Result" (also indicated by the number of warning lamp flashes in the Diagnosis mode) is displayed on the CONSULT screen in real time. This refers to a malfunctioning part requiring repairs.
"Data Monitor"	DATA MONITOR	Displays air bag diagnosis sensor unit input/output data in real time.
"ECU Identification"	ECU DISCRIMINATED NO.	Air bag diagnosis sensor unit ECU discriminated number (identification number) or part number is displayed. Air bag diagnosis sensor unit has individual ECU discriminated number (identification number) or part number based on model and equipment.
"TROUBLE DIAG RECORD"	TROUBLE DIAG RECORD [PAST]	With "TROUBLE DIAG RECORD", diagnosis results previously erased by a reset operation can be displayed on the CONSULT screen.

CONSULT Function (OCCUPANT DETECTION)

INFOID:000000012159653

CONSULT can display each diagnostic item using the diagnostic test modes shown following:

Diagnostic Test Mode	Diagnostic Item	Description
"Work support"	ZERO POINT RESET FUNCTION	Perform zero point reset. Refer to SRC-39. "ZERO POINT RESET : Special Repair Requirement" .

DIAGNOSIS SENSOR UNIT

< ECU DIAGNOSIS INFORMATION >

ECU DIAGNOSIS INFORMATION

DIAGNOSIS SENSOR UNIT

DTC Index

INFOID:000000012159654

DTC	Diagnostic item	Reference page
U1000-01	CAN COMM CIRCUIT	SRC-42. "Diagnosis Procedure"
U1010-49	CONTROL UNIT (CAN)	SRC-43. "Diagnosis Procedure"
B0001-00	DRIVER AIRBAG MODULE [SHORT]	SRC-45. "Diagnosis Procedure"
B0001-09	DRIVER AIRBAG MODULE [SHORT]	
B0001-11	DRIVER AIRBAG MODULE [GND-SHORT]	
B0001-12	DRIVER AIRBAG MODULE [VB-SHORT]	
B0001-13	DRIVER AIRBAG MODULE [OPEN]	
B0001-1A	DRIVER AIRBAG MODULE [SHORT]	
B0002-00	DRIVER AIRBAG MODULE 2 [SHORT]	SRC-45. "Diagnosis Procedure"
B0002-09	DRIVER AIRBAG MODULE 2 [SHORT]	
B0002-11	DRIVER AIRBAG MODULE 2 [GND-SHORT]	
B0002-12	DRIVER AIRBAG MODULE 2 [VB-SHORT]	
B0002-13	DRIVER AIRBAG MODULE 2 [OPEN]	
B0002-1A	DRIVER AIRBAG MODULE 2 [SHORT]	
B0010-09	ASSIST A/B MODULE [SHORT]	SRC-49. "Diagnosis Procedure"
B0010-11	ASSIST A/B MODULE [GND-SHORT]	
B0010-12	ASSIST A/B MODULE [VB-SHORT]	
B0010-13	ASSIST A/B MODULE [OPEN]	
B0010-1A	ASSIST A/B MODULE [SHORT]	
B0011-09	ASSIST A/B MODULE 2 [SHORT]	SRC-49. "Diagnosis Procedure"
B0011-11	ASSIST A/B MODULE 2 [GND-SHORT]	
B0011-12	ASSIST A/B MODULE 2 [VB-SHORT]	
B0011-13	ASSIST A/B MODULE 2 [OPEN]	
B0011-1A	ASSIST A/B MODULE 2 [SHORT]	
B0020-09	SIDE A/B MODULE LH [SHORT]	SRC-52. "Diagnosis Procedure"
B0020-11	SIDE A/B MODULE LH [GND-SHORT]	
B0020-12	SIDE A/B MODULE LH [VB-SHORT]	
B0020-13	SIDE A/B MODULE LH [OPEN]	
B0020-1A	SIDE A/B MODULE LH [SHORT]	SRC-58. "Diagnosis Procedure"
B0021-09	CURTAIN A/B MODULE LH [SHORT]	
B0021-11	CURTAIN A/B MODULE LH [GND-SHORT]	
B0021-12	CURTAIN A/B MODULE LH [VB-SHORT]	
B0021-13	CURTAIN A/B MODULE LH [OPEN]	
B0021-1A	CURTAIN A/B MODULE LH [SHORT]	

DIAGNOSIS SENSOR UNIT

< ECU DIAGNOSIS INFORMATION >

DTC	Diagnostic item	Reference page	
B0028-09	SIDE A/B MODULE RH [SHORT]	SRC-55, "Diagnosis Procedure"	A
B0028-11	SIDE A/B MODULE RH [GND-SHORT]		B
B0028-12	SIDE A/B MODULE RH [VB-SHORT]		
B0028-13	SIDE A/B MODULE RH [OPEN]		
B0028-1A	SIDE A/B MODULE RH [SHORT]		
B0029-09	CURTAIN A/B MODULE RH [SHORT]	SRC-61, "Diagnosis Procedure"	C
B0029-11	CURTAIN A/B MODULE RH [GND-SHORT]		D
B0029-12	CURTAIN A/B MODULE RH [VB-SHORT]		
B0029-13	CURTAIN A/B MODULE RH [OPEN]		
B0029-1A	CURTAIN A/B MODULE RH [SHORT]		
B0091-11	B-PILLAR SAT SEN LH [GND-SHORT]	SRC-69, "Diagnosis Procedure"	E
B0091-23	B-PILLAR SAT SEN LH [LOWER LIMIT ERR]		F
B0091-24	B-PILLAR SAT SEN LH [UPPER LIMIT ERR]		
B0091-25	B-PILLAR SAT SEN LH [SELF-DIAG ERR]		
B0091-28	B-PILLAR SAT SEN LH [OFFSET ERR]		
B0091-81	B-PILLAR SAT SEN LH [COMM ERR]		
B0091-86	B-PILLAR SAT SEN LH [UNMATCH]		
B0091-88	B-PILLAR SAT SEN LH [OPEN]		
B0091-93	B-PILLAR SAT SEN LH [RESET]		
B0092-11	C-PILLAR SAT SEN LH [GND-SHORT]	SRC-79, "Diagnosis Procedure"	
B0092-23	C-PILLAR SAT SEN LH [LOWER LIMIT ERR]		I
B0092-24	C-PILLAR SAT SEN LH [UPPER LIMIT ERR]		
B0092-25	C-PILLAR SAT SEN LH [SELF-DIAG ERR]		J
B0092-28	C-PILLAR SAT SEN LH [OFFSET ERR]		
B0092-81	C-PILLAR SAT SEN LH [COMM ERR]		
B0092-86	C-PILLAR SAT SEN LH [UNMATCH]		K
B0092-88	C-PILLAR SAT SEN LH [DISCONNECT]		
B0092-93	C-PILLAR SAT SEN LH [RESET]		
B0093-11	DOOR SATEL SENS LH [GND-SHORT]	SRC-88, "Diagnosis Procedure"	L
B0093-23	DOOR SATEL SENS LH [LOWER LIMIT ERR]		
B0093-24	DOOR SATEL SENS LH [UPPER LIMIT ERR]		M
B0093-25	DOOR SATEL SENS LH [SELF-DIAG ERR]		
B0093-28	DOOR SATEL SENS LH [OFFSET ERR]		
B0093-81	DOOR SATEL SENS LH [COMM ERR]		N
B0093-86	DOOR SATEL SENS LH [UNMATCH]		
B0093-88	DOOR SATEL SENS LH [OPEN]		O
B0093-93	DOOR SATEL SENS LH [RESET]		

SRC

DIAGNOSIS SENSOR UNIT

< ECU DIAGNOSIS INFORMATION >

DTC	Diagnostic item	Reference page
B0094-11	CRASH ZONE SENS [GND-SHORT]	SRC-64, "Diagnosis Procedure"
B0094-23	CRASH ZONE SENS [LOWER LIMIT ERR]	
B0094-24	CRASH ZONE SENS [UPPER LIMIT ERR]	
B0094-25	CRASH ZONE SENS [SELF-DIAG ERR]	
B0094-28	CRASH ZONE SENS [OFFSET ERR]	
B0094-81	CRASH ZONE SENS [COMM ERR]	
B0094-86	CRASH ZONE SENS [UNMATCH]	
B0094-88	CRASH ZONE SENS [OPEN]	
B0094-93	CRASH ZONE SENS [RESET]	
B0096-11	B-PILLAR SAT SEN RH [GND-SHORT]	SRC-75, "Diagnosis Procedure"
B0096-23	B-PILLAR SAT SEN RH [LOWER LIMIT ERR]	
B0096-24	B-PILLAR SAT SEN RH [UPPER LIMIT ERR]	
B0096-25	B-PILLAR SAT SEN RH [SELF-DIAG ERR]	
B0096-28	B-PILLAR SAT SEN RH [OFFSET ERR]	
B0096-81	B-PILLAR SAT SEN RH [COMM ERR]	
B0096-86	B-PILLAR SAT SEN RH [UNMATCH]	
B0096-88	B-PILLAR SAT SEN RH [OPEN]	
B0096-93	B-PILLAR SAT SEN RH [RESET]	
B0097-11	C-PILLAR SAT SEN RH [GND-SHORT]	SRC-83, "Diagnosis Procedure"
B0097-23	C-PILLAR SAT SEN RH [LOWER LIMIT ERR]	
B0097-24	C-PILLAR SAT SEN RH [UPPER LIMIT ERR]	
B0097-25	C-PILLAR SAT SEN RH [SELF-DIAG ERR]	
B0097-28	C-PILLAR SAT SEN RH [OFFSET ERR]	
B0097-81	C-PILLAR SAT SEN RH [COMM ERR]	
B0097-86	C-PILLAR SAT SEN RH [UNMATCH]	
B0097-88	C-PILLAR SAT SEN RH [OPEN]	
B0097-93	C-PILLAR SAT SEN RH [RESET]	
B0098-11	DOOR SATEL SENS RH [GND-SHORT]	SRC-92, "Diagnosis Procedure"
B0098-23	DOOR SATEL SENS RH [LOWER LIMIT ERR]	
B0098-24	DOOR SATEL SENS RH [UPPER LIMIT ERR]	
B0098-25	DOOR SATEL SENS RH [SELF-DIAG ERR]	
B0098-28	DOOR SATEL SENS RH [OFFSET ERR]	
B0098-81	DOOR SATEL SENS RH [COMM ERR]	
B0098-86	DOOR SATEL SENS RH [UNMATCH]	
B0098-88	DOOR SATEL SENS RH [OPEN]	
B0098-93	DOOR SATEL SENS RH [RESET]	

DIAGNOSIS SENSOR UNIT

< ECU DIAGNOSIS INFORMATION >

DTC	Diagnostic item	Reference page
B00A0-00	OCCUPANT SENS [ABNORMAL VOLTAGE]	SRC-96, "Diagnosis Procedure (B00A0-00, -02 or -09)", SRC-97, "Diagnosis Procedure (B00A0-04)", SRC-98, "Diagnosis Procedure (B00A0-83, -86, -87, -88 or -8F)", SRC-99, "Diagnosis Procedure (B00A0-93)"
B00A0-02	OCCUPANT SENS [UNIT MALFUNC]	
B00A0-09	OCCUPANT SENS [UNIT MALFUNC]	
B00A0-04	OCCUPANT SENS C/U [UNIT MALFUNC]	
B00A0-83	OCCUPANT SENS C/U [COMM ERR]	
B00A0-86	OCCUPANT SENS C/U [COMM ERR]	
B00A0-87	OCCUPANT SENS C/U [COMM ERR]	
B00A0-88	OCCUPANT SENS C/U [COMM ERR]	
B00A0-8F	OCCUPANT SENS C/U [UNDEFINED]	
B00A0-93	OCCUPANT SENS C/U [RESET]	
B00D5-04	PASS A/B INDCTR CKT [UNIT MALFUNC]	SRC-103, "Diagnosis Procedure"
B00D5-11	PASS A/B INDCTR CKT [GND-SHORT]	
B00D5-12	PASS A/B INDCTR CKT [VB-SHORT]	
B00D5-13	PASS A/B INDCTR CKT [OPEN]	
B00D5-15	PASS A/B INDCTR CKT [PWR-SHORT/OPEN]	
B1428-13	BUCKLE SW LH CIRCUIT [OPEN]	SRC-106, "Diagnosis Procedure"
B1428-12	BUCKLE SW LH CIRCUIT [VB-SHORT]	
B1428-11	BUCKLE SW LH CIRCUIT [GND-SHORT]	
B1428-00	BUCKLE SW LH CIRCUIT [UNDEFINED]	
B1429-13	BUCKLE SW RH CIRCUIT [OPEN]	SRC-109, "Diagnosis Procedure"
B1429-12	BUCKLE SW RH CIRCUIT [VB-SHORT]	
B1429-11	BUCKLE SW RH CIRCUIT [GND-SHORT]	
B1429-00	BUCKLE SW RH CIRCUIT [UNDEFINED]	
B1430-09	PRE-TEN FRONT LH [SHORT]	SRC-112, "Diagnosis Procedure"
B1430-11	PRE-TEN FRONT LH [GND-SHORT]	
B1430-12	PRE-TEN FRONT LH [VB-SHORT]	
B1430-13	PRE-TEN FRONT LH [OPEN]	
B1430-1A	PRE-TEN FRONT LH [SHORT]	
B1431-09	PRE-TEN FRONT RH [SHORT]	SRC-115, "Diagnosis Procedure"
B1431-11	PRE-TEN FRONT RH [GND-SHORT]	
B1431-12	PRE-TEN FRONT RH [VB-SHORT]	
B1431-13	PRE-TEN FRONT RH [OPEN]	
B1431-1A	PRE-TEN FRONT RH [SHORT]	
B1432-09	PRE-TEN FRONT RH [SHORT]	SRC-115, "Diagnosis Procedure"
B1432-11	PRE-TEN FRONT RH [GND-SHORT]	
B1432-12	PRE-TEN FRONT RH [VB-SHORT]	
B1432-13	PRE-TEN FRONT RH [OPEN]	
B1432-1A	PRE-TEN FRONT RH [SHORT]	
B1433-09	PRE-TEN FRONT RH 2 [SHORT]	SRC-121, "Diagnosis Procedure"
B1433-11	PRE-TEN FRONT RH 2 [GND-SHORT]	
B1433-12	PRE-TEN FRONT RH 2 [VB-SHORT]	
B1433-13	PRE-TEN FRONT RH 2 [OPEN]	
B1433-1A	PRE-TEN FRONT RH 2 [SHORT]	

A

B

C

D

E

F

G

SRC

I

J

K

L

M

N

O

P

DIAGNOSIS SENSOR UNIT

< ECU DIAGNOSIS INFORMATION >

DTC	Diagnostic item	Reference page
B1436-09	ACTIVE VENT [SHORT]	SRC-124, "Diagnosis Procedure"
B1436-11	ACTIVE VENT [GND-SHORT]	
B1436-12	ACTIVE VENT [VB-SHORT]	
B1436-13	ACTIVE VENT [OPEN]	
B1436-1A	ACTIVE VENT [SHORT]	
B142A-16	IGNITION VOLTAGE [VB-LOW]	SRC-127, "Diagnosis Procedure"
B142A-17	IGNITION VOLTAGE [VB-HIGH]	
B1400-00	CONTROL UNIT [UNIT MALFUNC]	SRC-131, "Diagnosis Procedure"
B1401-00		
B1402-00		
B1403-00		
B1404-00		
B1405-00		SRC-133, "Diagnosis Procedure"
B1406-00		
B1407-00		
B1408-00		
B1409-00		
B1410-00		SRC-134, "Diagnosis Procedure"
B1411-00		
B1412-00		
B1413-00		
B1414-00		
B1415-00		SRC-137, "Diagnosis Procedure"
B1416-00		
B1417-00		
B1418-00		
B1419-00		
B1420-00		
B1421-00	FRONTAL COLLISION	SRC-131, "Diagnosis Procedure"
B1422-00	SIDE COLLISION	
B1423-00	ROLLOVER DETECTION	
B1425-00	REAR COLLISION	
B14XX-00	AIRBAG DISPOSAL COMPLETION	SRC-141, "Diagnosis Procedure"
B1426-00	AIRBAG DISPOSAL DETECT	
B1427-55	ECU SETTING	SRC-129, "Diagnosis Procedure"

SRS AIR BAG SYSTEM

< WIRING DIAGRAM >

WIRING DIAGRAM

SRS AIR BAG SYSTEM

Wiring Diagram

INFOID:000000012159655

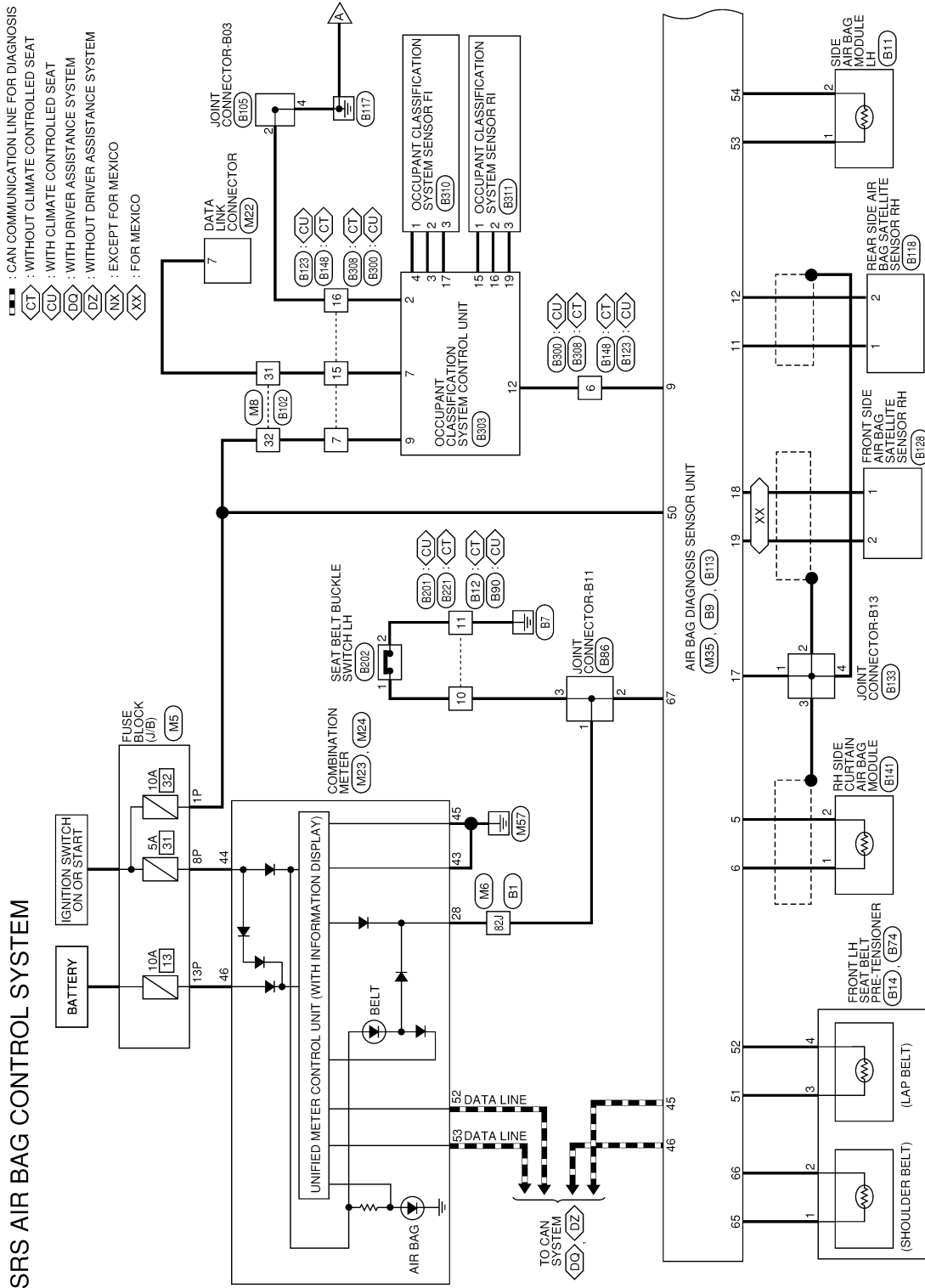

*: THIS CONNECTOR IS NOT SHOWN IN "HARNESS LAYOUT" OF PG SECTION.

AAHWA0171GB

A
B
C
D
E
F
G
H
I
J
K
L
M
N
O
P

SRC

SRS AIR BAG SYSTEM

< WIRING DIAGRAM >

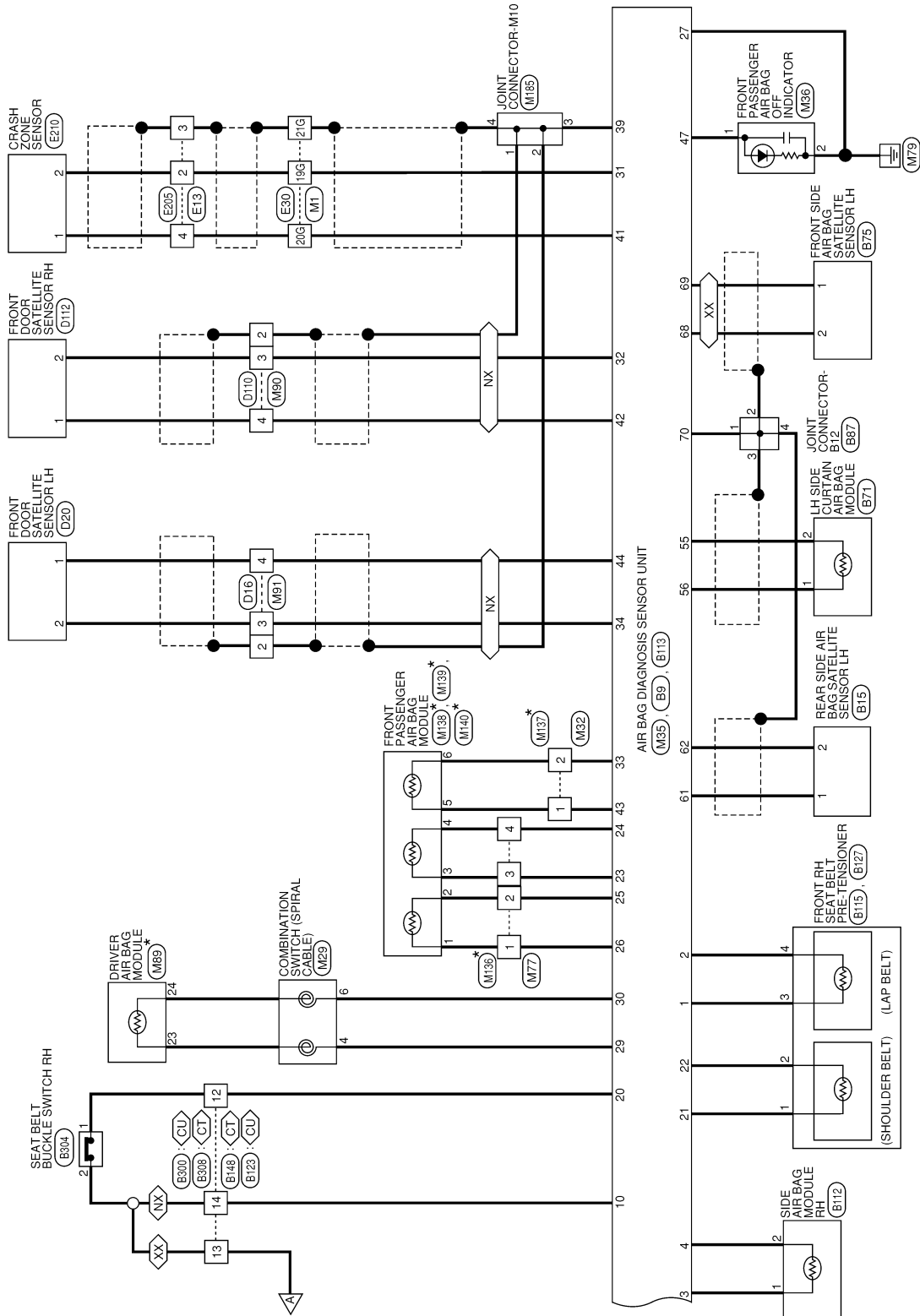

AAHWA0172GB

SRS AIR BAG SYSTEM

< WIRING DIAGRAM >

SRS AIR BAG CONTROL SYSTEM CONNECTORS

Connector No.	M1
Connector Name	WIRE TO WIRE
Connector Type	TH80FW-CS16-TM4
Connector Color	WHITE

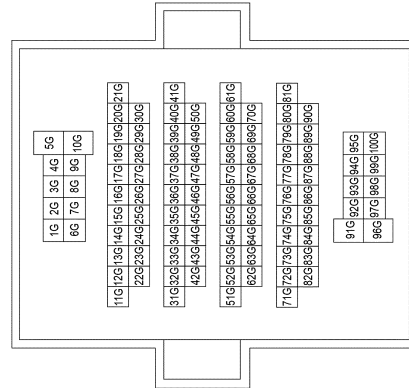

Terminal No.	Color of Wire	Signal Name
19G	B	-
20G	W	-
21G	SHIELD	-

Connector No.	M5
Connector Name	FUSE BLOCK (J/B)
Connector Type	NS16FW-CS
Connector Color	WHITE

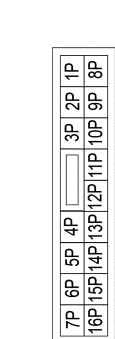

Terminal No.	Color of Wire	Signal Name
1P	P	-
8P	BR	-
13P	G	-

Connector No.	M6
Connector Name	WIRE TO WIRE
Connector Type	TH80FDGY-CS16-TM4
Connector Color	GRAY

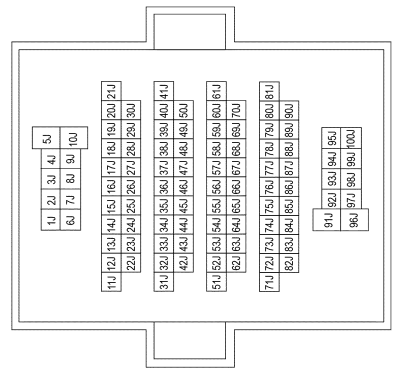

Terminal No.	Color of Wire	Signal Name
82U	LG	-

Connector No.	M8
Connector Name	WIRE TO WIRE
Connector Type	TH32FW-NH
Connector Color	WHITE

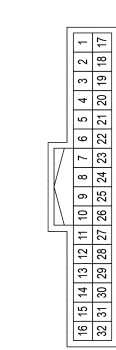

Terminal No.	Color of Wire	Signal Name
31	R	-
32	P	-

Connector No.	M22
Connector Name	DATA LINK CONNECTOR
Connector Type	BD16FW
Connector Color	WHITE

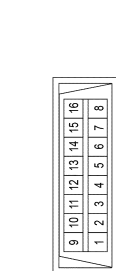

Terminal No.	Color of Wire	Signal Name
7	R	-

Connector No.	M23
Connector Name	COMBINATION METER
Connector Type	TH16FW-NH
Connector Color	WHITE

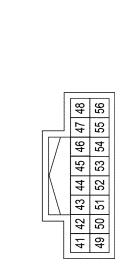

Terminal No.	Color of Wire	Signal Name
43	B	GND1
44	BR	POWER (IGN)
45	B	GND2
46	G	POWER (BAT)
52	P	CAN-L
53	L	CAN-H

A
B
C
D
E
F
G
H
I
J
K
L
M
N
O
P

SRC

SRS AIR BAG SYSTEM

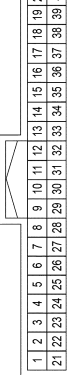

< WIRING DIAGRAM >

Connector No.	M24
Connector Name	COMBINATION METER
Connector Type	TH40FW-NH
Connector Color	WHITE



Terminal No.	28	Color of Wire	LG	Signal Name	SEAT BELT SW (DR)
--------------	----	---------------	----	-------------	-------------------

Connector No.	M29
Connector Name	COMBINATION SWITCH (SPIRAL CABLE)
Connector Type	TK06FY-EX-1V
Connector Color	YELLOW

Terminal No.	4	Color of Wire	Y	Signal Name	-
6	LG	-	-	-	

Connector No.	M32
Connector Name	WIRE TO WIRE
Connector Type	TK02FY-EX-1V
Connector Color	YELLOW



Terminal No.	1	Color of Wire	LG	Signal Name	-
2	BR	-	-	-	

Connector No.	M35
Connector Name	AIR BAG DIAGNOSIS SENSOR UNIT
Connector Type	NH28FY-EX
Connector Color	YELLOW

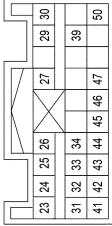
Terminal No.	23	Color of Wire	SB	Signal Name	AS2+
24	Y	AS2-			
25	V	AS1-			
26	L	AS1+			
27	B	GND			
28	-	-			
29	Y	DR1-			
30	LG	DR1+			
31	B	ECZS 1-			
32	B	RH DOOR SATELLITE SENSOR-			
33	BR	ACT VENT-			
34	B	LH DOOR SATELLITE SENSOR-			
35	-	-			
36	-	-			
37	-	-			
38	-	-			
39	GR	GND			
40	-	-			
41	W	ECZS 1+			
42	W	RH DOOR SATELLITE SENSOR+			
43	LG	ACT VENT+			
44	W	LH DOOR SATELLITE SENSOR+			
45	P	CAN-L			
46	L	CAN-H			
47	R	TELLTALE LAMP			
48	-	-			
49	-	-			
50	P	IGN			

Connector No.	M36
Connector Name	FRONT PASSENGER AIR BAG OFF INDICATOR
Connector Type	TK02FBR
Connector Color	BROWN

Terminal No.	1	Color of Wire	R	Signal Name	-
2	GR	-	-	-	

Connector No.	M77
Connector Name	WIRE TO WIRE
Connector Type	RK04FY-BD
Connector Color	YELLOW



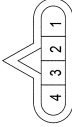

Terminal No.	1	Color of Wire	L	Signal Name	-
2	V	-	-	-	
3	SB	-	-	-	
4	Y	-	-	-	

SRS AIR BAG SYSTEM

< WIRING DIAGRAM >

Connector No.	M138
Connector Name	PASSENGER AIR BAG MODULE
Connector Type	ACA02FY-2V
Connector Color	YELLOW



Terminal No.	Color of Wire	Signal Name
1	L	-
2	L	-

Connector No.	M139
Connector Name	PASSENGER AIR BAG MODULE
Connector Type	ACA02FG-2V
Connector Color	GREEN

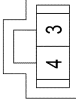
Terminal No.	Color of Wire	Signal Name
3	R	-
4	R	-

Connector No.	M140
Connector Name	PASSENGER AIR BAG MODULE
Connector Type	ACA02FOR-2V
Connector Color	ORANGE

Terminal No.	Color of Wire	Signal Name
5	Y	-
6	Y	-



4	W	-
---	---	---

Connector No.	M136
Connector Name	WIRE TO WIRE
Connector Type	RK04MY-BD
Connector Color	YELLOW

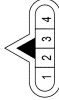

Terminal No.	Color of Wire	Signal Name
1	L	-
2	L	-
3	R	-
4	R	-

Connector No.	M137
Connector Name	WIRE TO WIRE
Connector Type	TK02MY-EX-1V
Connector Color	YELLOW

Terminal No.	Color of Wire	Signal Name
1	Y	-
2	Y	-

Connector No.	M89
Connector Name	DRIVER AIRBAG MODULE
Connector Type	ACA02FY-2V
Connector Color	YELLOW

Terminal No.	Color of Wire	Signal Name
23	Y	-
24	R	-

Connector No.	M90
Connector Name	WIRE TO WIRE
Connector Type	TK04MY-BD
Connector Color	YELLOW

Terminal No.	Color of Wire	Signal Name
2	SHIELD	-
3	B	-
4	W	-

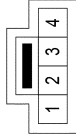
Connector No.	M91
Connector Name	WIRE TO WIRE
Connector Type	TK04MY-BD
Connector Color	YELLOW

Terminal No.	Color of Wire	Signal Name
2	SHIELD	-
3	B	-

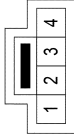
AAHIA0528GB

A
B
C
D
E
F
G
H
I
J
K
L
M
N
O
P

SRC

SRS AIR BAG SYSTEM

< WIRING DIAGRAM >

Connector No.	E210
Connector Name	CRASH ZONE SENSOR
Connector Type	HK02FY-1V-EX
Connector Color	YELLOW



Terminal No.	Color of Wire	Signal Name
1	W	-
2	B	-

Connector No.	B1
Connector Name	WIRE TO WIRE
Connector Type	TH80MDGY-CS16-TM4
Connector Color	GRAY

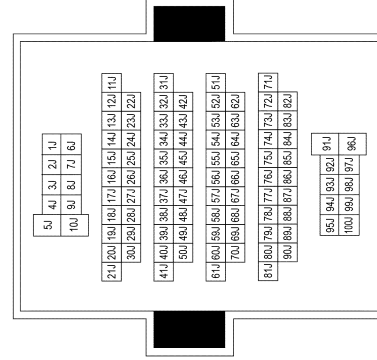

Terminal No.	Color of Wire	Signal Name
82J	LG	-

Connector No.	E30
Connector Name	WIRE TO WIRE
Connector Type	TH80MMW-CS16-TM4
Connector Color	WHITE

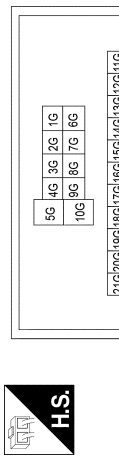

Terminal No.	Color of Wire	Signal Name
19G	B	-
20G	W	-
21G	SHIELD	-

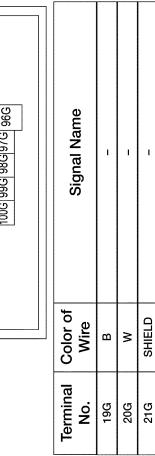

Connector No.	E205
Connector Name	WIRE TO WIRE
Connector Type	TK04FY
Connector Color	YELLOW

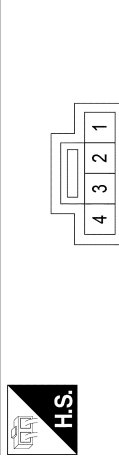

Terminal No.	Color of Wire	Signal Name
2	B	-
3	SHIELD	-
4	W	-

Connector No.	M185
Connector Name	JOINT CONNECTOR-M10
Connector Type	TK04FW-J
Connector Color	WHITE

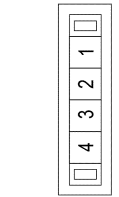

Terminal No.	Color of Wire	Signal Name
1	SHIELD	-
2	SHIELD	-
3	GR	-
4	SHIELD	-

Connector No.	E13
Connector Name	WIRE TO WIRE
Connector Type	TK04MY-BD
Connector Color	YELLOW

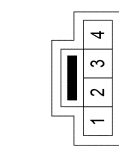

Terminal No.	Color of Wire	Signal Name
2	B	-
3	SHIELD	-
4	W	-

AAHIA0578GB

SRS AIR BAG SYSTEM

< WIRING DIAGRAM >

Connector No.	B15
Connector Name	REAR SIDE AIR BAG SATELLITE SENSOR LH
Connector Type	HK02FY-1V-EX
Connector Color	YELLOW



Terminal No.	Color of Wire	Signal Name
1	W	-
2	B	-

Connector No.	B71
Connector Name	LH SIDE CURTAIN AIR BAG MODULE
Connector Type	ACB02FY
Connector Color	YELLOW



Terminal No.	Color of Wire	Signal Name
1	B	-
2	W	-

2	BR	-
Connector No.	B12	
Connector Name	WIRE TO WIRE	
Connector Type	NS12FW-CS	
Connector Color	WHITE	



Terminal No.	Color of Wire	Signal Name
10	LG	-
11	B	-

Connector No.	B14
Connector Name	FRONT LH SEAT BELT PRE-TENSIONER (SHOULDER BELT)
Connector Type	ACB02FY
Connector Color	YELLOW



Terminal No.	Color of Wire	Signal Name
1	G	-
2	P	-

Connector No.	B9
Connector Name	AIR BAG DIAGNOSIS SENSOR UNIT
Connector Type	NH22FY-2V-EX
Connector Color	YELLOW

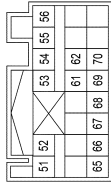

Terminal No.	Color of Wire	Signal Name
51	R	P-LH2(+)
52	BG	P-LH2(-)
53	Y	SLH(+)
54	BR	SLH(-)
55	W	C-LH1-
56	B	C-LH1+
57	-	-
58	-	-
59	-	-
60	-	-
61	W	LH C-PILLAR SATELLITE SENSOR +
62	B	LH C-PILLAR SATELLITE SENSOR -
63	-	-
64	-	-
65	G	P-LH1+
66	P	P-LH1-
67	LG	LH SEAT BELT BUCKLE SWITCH+
68	B	LH B-PILLAR SATELLITE SENSOR -
69	W	LH B-PILLAR SATELLITE SENSOR +
70	GR	GND
71	-	-
72	-	-

Connector No.	B11
Connector Name	SIDE AIR BAG MODULE LH
Connector Type	TK02FY-EX-1V
Connector Color	YELLOW



Terminal No.	Color of Wire	Signal Name
1	Y	-

A
B
C
D
E
F
G
H
I
J
K
L
M
N
O
P

SRC

AAHIA0530GB

SRS AIR BAG SYSTEM

< WIRING DIAGRAM >

Connector No.	B102
Connector Name	WIRE TO WIRE
Connector Type	TH32MW-NH
Connector Color	WHITE

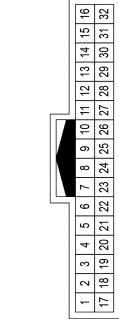

Terminal No.	Color of Wire	Signal Name
31	BG	-
32	LG	-

Connector No.	B105
Connector Name	JOINT CONNECTOR-B03
Connector Type	TK04FW-J
Connector Color	WHITE

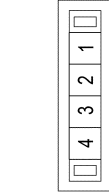

Terminal No.	Color of Wire	Signal Name
2	B	-
4	B	-

Connector No.	B112
Connector Name	SIDE AIR BAG MODULE RH
Connector Type	TK02FY-EX-IV
Connector Color	YELLOW

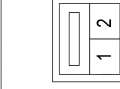

Terminal No.	Color of Wire	Signal Name
1	Y	-
2	BR	-

2	LG	-
3	LG	-

Connector No.	B87
Connector Name	JOINT CONNECTOR-B12
Connector Type	TK04FW-J
Connector Color	WHITE

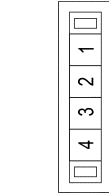

Terminal No.	Color of Wire	Signal Name
1	GR	-
2	SHIELD	-
3	SHIELD	-
4	SHIELD	-

Connector No.	B90
Connector Name	WIRE TO WIRE
Connector Type	NS12FW-CS
Connector Color	WHITE

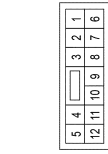

Terminal No.	Color of Wire	Signal Name
10	LG	-
11	B	-

Connector No.	B74
Connector Name	FRONT LH SEAT BELT PRE-TENSIONER (LAP BELT)
Connector Type	ACB02FOR
Connector Color	ORANGE

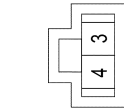

Terminal No.	Color of Wire	Signal Name
3	R	-
4	BG	-

Connector No.	B75
Connector Name	FRONT SIDE AIR BAG SATELLITE SENSOR LH
Connector Type	HK02FY-1V-EX
Connector Color	YELLOW

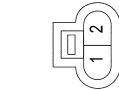

Terminal No.	Color of Wire	Signal Name
1	W	-
2	B	-

Connector No.	B86
Connector Name	JOINT CONNECTOR-B11
Connector Type	TK04FW-J
Connector Color	WHITE

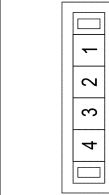

Terminal No.	Color of Wire	Signal Name
1	LG	-

AAHIA0531GB

SRS AIR BAG SYSTEM

< WIRING DIAGRAM >

Connector No.	B127
Connector Name	FRONT RH SEAT BELT PRE-TENSIONER (LAP BELT)
Connector Type	ACB02FOR
Connector Color	ORANGE

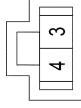

Terminal No.	Color of Wire	Signal Name
3	R	-
4	BG	-

Connector No.	B128
Connector Name	FRONT SIDE AIR BAG SATELLITE SENSOR RH
Connector Type	HK02FY-1V-EX
Connector Color	YELLOW



Terminal No.	Color of Wire	Signal Name
1	B	-
2	W	-

1	G
2	P

Connector No.	B118
Connector Name	REAR SIDE AIR BAG SATELLITE SENSOR RH
Connector Type	HK02FY-1V-EX
Connector Color	YELLOW



Terminal No.	Color of Wire	Signal Name
1	B	-
2	W	-

Connector No.	B123
Connector Name	WIRE TO WIRE
Connector Type	NS16FW-CS
Connector Color	WHITE

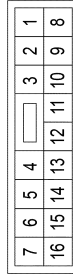

Terminal No.	Color of Wire	Signal Name
6	-	-
7	-	-
12	L	-
13	B	-
14	-	-
15	-	-
16	-	-

Connector No.	B113
Connector Name	AIR BAG DIAGNOSIS SENSOR UNIT
Connector Type	NH22FY-1V-EX
Connector Color	YELLOW

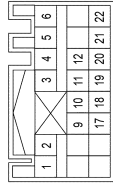

Terminal No.	Color of Wire	Signal Name
1	R	P-RH2+
2	BG	P-RH2-
3	Y	S-RH+
4	BR	S-RH-
5	W	C-RH-
6	B	C-RH+
7	-	-
8	-	-
9	L	ODS INPUT
10	Y	RH SEAT BELT BUCKLE SWITCH -
11	B	RH C-PILLAR SATELLITE SENSOR+
12	W	RH C-PILLAR SATELLITE SENSOR-
13	-	-
14	-	-
15	-	-
16	-	-
17	GR	GND
18	B	RH B-PILLAR SATELLITE SENSOR+
19	W	RH B-PILLAR SATELLITE SENSOR-
20	L	RH SEAT BELT BUCKLE SWITCH+
21	G	P-RH1+
22	P	P-RH1-



Connector No.	B115
Connector Name	FRONT RH SEAT BELT PRE-TENSIONER (SHOULDER BELT)
Connector Type	ACB02FY
Connector Color	YELLOW

Terminal No.	Color of Wire	Signal Name
--------------	---------------	-------------

AAHIA0579GB

A
B
C
D
E
F
G
H
I
J
K
L
M
N
O
P

SRC

SRS AIR BAG SYSTEM

< WIRING DIAGRAM >

Connector No.	B221
Connector Name	WIRE TO WIRE
Connector Type	NS12MW-CS
Connector Color	WHITE



1	2	3	4	5
6	7	8	9	10
11	12			

Terminal No.	Color of Wire	Signal Name
10	-	-
11	B	-

Connector No.	B300
Connector Name	WIRE TO WIRE
Connector Type	NS16MW-CS
Connector Color	WHITE



1	2	3	4	5	6	7
8	9	10	11	12	13	14
15	16					

Terminal No.	Color of Wire	Signal Name
6	BRW	-
7	W	-
12	L	-
13	B	-
14	Y	- (EXCEPT MEXICO)
15	GR	-
16	B	-

7	LG	-
12	L	-
13	B	- (FOR MEXICO)
14	Y	- (EXCEPT MEXICO)
15	BG	-
16	B	-

Connector No.	B201
Connector Name	WIRE TO WIRE
Connector Type	NS12MW-CS
Connector Color	WHITE



1	2	3	4	5
6	7	8	9	10
11	12			

Terminal No.	Color of Wire	Signal Name
10	L	-
11	B	-

Connector No.	B202
Connector Name	SEAT BELT BUCKLE SWITCH LH
Connector Type	TH04FW-NH
Connector Color	WHITE



4	3	2	1
---	---	---	---

Terminal No.	Color of Wire	Signal Name
1	L	-
2	B	-

Connector No.	B133
Connector Name	JOINT CONNECTOR-B13
Connector Type	TK04FW-J
Connector Color	WHITE



4	3	2	1
---	---	---	---

Terminal No.	Color of Wire	Signal Name
1	GR	-
2	SHIELD	-
3	SHIELD	-
4	SHIELD	-

Connector No.	B141
Connector Name	RH SIDE CURTAIN AIR BAG MODULE
Connector Type	ACB02FY
Connector Color	YELLOW



2	1
---	---

Terminal No.	Color of Wire	Signal Name
1	B	-
2	W	-

Connector No.	B148
Connector Name	WIRE TO WIRE
Connector Type	NS16FW-CS
Connector Color	WHITE



7	6	5	4	3	2	1
16	15	14	13	12	11	10
9	8					

Terminal No.	Color of Wire	Signal Name
6	L	-

AAHIA0580GB

SRS AIR BAG SYSTEM

< WIRING DIAGRAM >

Connector No.	B311
Connector Name	OCCUPANT CLASSIFICATION SYSTEM SENSOR RI
Connector Type	HS3P
Connector Color	BLACK

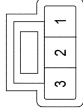

Terminal No.	Color of Wire	Signal Name
1	W/L	-
2	SB	-
3	Y	-

Connector No.	D16
Connector Name	WIRE TO WIRE
Connector Type	TK04FY
Connector Color	YELLOW

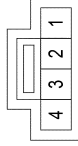

Terminal No.	Color of Wire	Signal Name
2	SHIELD	-
3	B	-
4	W	-

2	B
---	---

Connector No.	B308
Connector Name	WIRE TO WIRE
Connector Type	NS16MW-CS
Connector Color	WHITE

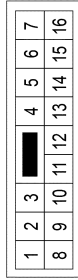

Terminal No.	Color of Wire	Signal Name
6	BRW	-
7	W	-
12	L	-
13	B	-
14	Y	(EXCEPT MEX/CO)
15	GR	-
16	B	-

Connector No.	B310
Connector Name	OCCUPANT CLASSIFICATION SYSTEM SENSOR FI
Connector Type	HS3P
Connector Color	BLACK

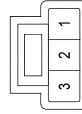

Terminal No.	Color of Wire	Signal Name
1	R/B	-
2	LG	-
3	R	-

Connector No.	B303
Connector Name	OCCUPANT CLASSIFICATION SYSTEM CONTROL UNIT
Connector Type	HU16MB-X
Connector Color	BLACK

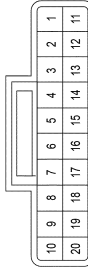

Terminal No.	Color of Wire	Signal Name
1	-	-
2	B	GND
3	LG	LOAD SENSOR FRONT INNER SIGNAL
4	R/B	LOAD SENSOR FRONT INNER GND
5	-	-
6	-	-
7	GR	K-LINE
8	-	-
9	W	IGN
10	-	-
11	-	-
12	BRW	ACU COMM
13	-	-
14	-	-
15	W/L	LOAD SENSOR REAR INNER GND
16	SB	LOAD SENSOR REAR INNER SIGNAL
17	R	LOAD SENSOR FRONT INNER VCC
18	-	-
19	Y	LOAD SENSOR REAR INNER VCC
20	-	-

Connector No.	B304
Connector Name	SEAT BELT BUCKLE SWITCH RH
Connector Type	TH04FW-NH
Connector Color	WHITE

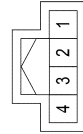

Terminal No.	Color of Wire	Signal Name
1	L	-

AAHIA0581GB

A
B
C
D
E
F
G
H
I
J
K
L
M
N
O
P

SRC

SRS AIR BAG SYSTEM

< WIRING DIAGRAM >

2	B	-
---	---	---

Connector No.	D20
Connector Name	FRONT DOOR SATELLITE SENSOR LH
Connector Type	HK02FY-1V-EX
Connector Color	YELLOW



Terminal No.	Color of Wire	Signal Name
1	W	-
2	B	-

Connector No.	D110
Connector Name	WIRE TO WIRE
Connector Type	TK04FY
Connector Color	YELLOW

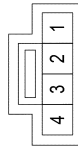

Terminal No.	Color of Wire	Signal Name
2	SHIELD	-
3	B	-
4	W	-

Connector No.	D112
Connector Name	FRONT DOOR SATELLITE SENSOR RH
Connector Type	HK02FY-1V-EX
Connector Color	YELLOW



Terminal No.	Color of Wire	Signal Name
1	W	-

AAHIA0577GB

DIAGNOSIS AND REPAIR WORK FLOW

< BASIC INSPECTION >

BASIC INSPECTION

DIAGNOSIS AND REPAIR WORK FLOW

Work Flow

INFOID:000000012159656

OVERALL SEQUENCE

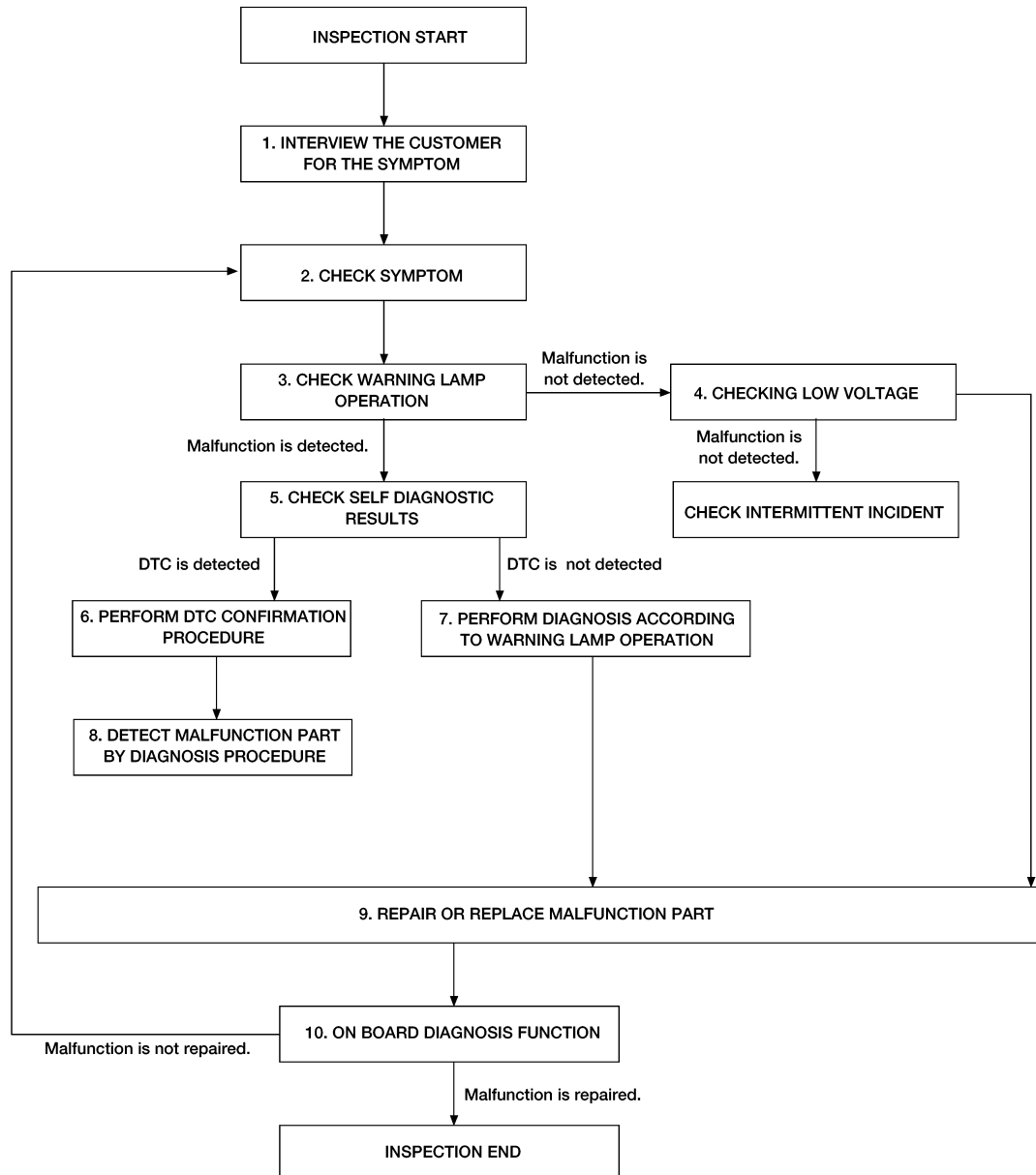

A
B
C
D
E
F
G
H
I
J
K
L
M
N
O
P

SRC

AWHIA0555GB

DETAILED FLOW

DIAGNOSIS AND REPAIR WORK FLOW

< BASIC INSPECTION >

1. INTERVIEW THE CUSTOMER FOR THE SYMPTOM

Interview the customer for the symptom (the condition and the environment when the incident/malfunction occurs).

>> GO TO 2.

2. CHECK SYMPTOM

Check the symptom from the customer information.

>> GO TO 3.

3. CHECK WARNING LAMP OPERATION

Check air bag warning lamp operation in the user mode.

Are any malfunctions detected?

YES >> GO TO 5.

NO >> GO TO 4.

4. CHECK LOW VOLTAGE

Check low voltage with CONSULT.

Are any malfunctions detected?

YES >> GO TO 9.

NO >> Check intermittent incident. Refer to [GI-41, "Intermittent Incident"](#).

5. CHECK SELF DIAGNOSTIC RESULT

Check "Self Diagnostic Result" with CONSULT or diagnosis mode.

If it is impossible to switch to diagnosis mode, follow the same procedure that DTC is not detected.

NOTE:

Perform the following procedure if DTC is detected:

- Record DTC. (Print them out with CONSULT.)
- Erase "Self Diagnostic Result".
- Study the relationship between the malfunction that DTC or air bag warning lamp indicates and the symptom that the customer describes.
- Check related service bulletins for information.

Is DTC detected?

YES >> GO TO 6.

NO >> GO TO 7.

6. PERFORM DTC CONFIRMATION PROCEDURE

Perform DTC CONFIRMATION PROCEDURE for the DTC.

>> GO TO 8.

7. PERFORM DIAGNOSIS ACCORDING TO WARNING LAMP OPERATION

1. Check air bag warning lamp operation in the user mode.
2. Perform Diagnosis Procedure for the air bag warning lamp operation.

>> GO TO 9.

8. DETECT MALFUNCTIONING PART BY DIAGNOSTIC PROCEDURE

Inspect according to Diagnostic Procedure of the DTC.

>> GO TO 9.

9. REPAIR OR REPLACE THE MALFUNCTION PART

Repair or replace the malfunctioning part.

DIAGNOSIS AND REPAIR WORK FLOW

< BASIC INSPECTION >

>> GO TO 10.

10.ON BOARD DIAGNOSIS FUNCTION

Check "Self Diagnostic Result" and air bag warning lamp operation in the user mode.

Is the malfunction repaired?

YES >> Inspection End.

NO >> GO TO 2.

A

B

C

D

E

F

G

SRC

I

J

K

L

M

N

O

P

INSPECTION AND ADJUSTMENT

< BASIC INSPECTION >

INSPECTION AND ADJUSTMENT

ADDITIONAL SERVICE WHEN REPLACING CONTROL UNIT

ADDITIONAL SERVICE WHEN REPLACING CONTROL UNIT : Description

INFOID:000000012159657

AIR BAG DIAGNOSIS SENSOR UNIT

Before Replacement

When replacing air bag diagnosis sensor unit, save or print current vehicle specification with CONSULT configuration before replacement.

NOTE:

If “Before Replace ECU” of “Read / Write Configuration” cannot be used, use the “Manual Configuration” after replacing air bag diagnosis sensor unit.

After Replacement

CAUTION:

Follow the instructions listed below. Failure to do this may cause malfunctions to the air bag diagnosis sensor unit.

- Never perform “Read / Write Configuration” or “Manual Configuration” except for new air bag diagnosis sensor unit.
- When replacing air bag diagnosis sensor unit, you must perform “Read / Write Configuration” or “Manual Configuration” with CONSULT.
- Complete the procedure of “Read / Write Configuration” or “Manual Configuration” in order.
- If you set incorrect “Read / Write Configuration” or “Manual Configuration”, incidents might occur.
- Configuration is different for each vehicle model. Confirm configuration of each vehicle model.

OCS CONTROL UNIT

WARNING:

Always perform zero point reset using CONSULT when removing and installing the front passenger seat or servicing the occupant classification system (OCS). If zero point reset is not performed, the OCS may not operate normally, which may increase the risk of serious injury in a collision.

ADDITIONAL SERVICE WHEN REPLACING CONTROL UNIT : Special Repair Requirement

INFOID:000000012159658

WORK PROCEDURE WHEN REPLACING AIR BAG DIAGNOSIS SENSOR UNIT

1. SAVING VEHICLE SPECIFICATION

ⓐCONSULT Configuration

Perform “Before Replace ECU” of “Read / Write Configuration” to save or print current vehicle specification.

NOTE:

If “Before Replace ECU” of “Read / Write Configuration” cannot be used, use the “Manual Configuration” after replacing air bag diagnosis sensor unit.

>> GO TO 2.

2. REPLACE AIR BAG DIAGNOSIS SENSOR UNIT

Replace air bag diagnosis sensor unit. Refer to [SR-27, "Removal and Installation"](#).

>> GO TO 3.

3. WRITING VEHICLE SPECIFICATION

ⓐCONSULT Configuration

Perform “After Replace ECU” of “Read / Write Configuration” or “Manual Configuration” to write vehicle specification. Refer to [SRC-39, "CONFIGURATION : Work Procedure"](#).

>> Work End.

INSPECTION AND ADJUSTMENT

< BASIC INSPECTION >

WORK PROCEDURE WHEN REPLACING OCS CONTROL UNIT

1.PERFORM ZERO POINT RESET

Perform zero point reset. Refer to [SRC-39. "ZERO POINT RESET : Special Repair Requirement"](#).

>> Inspection End.

ZERO POINT RESET

ZERO POINT RESET : Description

INFOID:000000012159659

Zero point reset is an initializing procedure for the OCS (weight) sensors that must be performed using CONSULT when removing and installing passenger seat or servicing the OCS system, including removing or installing OCS control unit and sensors. If zero point reset is not performed, the initialization is incomplete and OCS may not operate normally.

NOTE:

- When reinstalling the passenger seat, the initial value for the OCS sensors may change, and the OCS may not operate normally.
- When zero point reset is performed after removal and installation of passenger seat, CONSULT displays "complete".

ZERO POINT RESET : Special Repair Requirement

INFOID:000000012159660

1.PERFORM ZERO POINT RESET

CONSULT

1. Perform preliminary checks.

NOTE:

- Level the vehicle.
 - Minimize vibrations near the vehicle.
 - Remove any objects on passenger seat.
 - Do not touch the vehicle during zero point reset.
2. Select "Start" on "Zero point reset function" from "Work support" of "OCCUPANT DETECTION".
 3. "Zero point reset function" starts.

>> GO TO 2.

2.CONFIRM RESET

1. Check that "Complete" is displayed on "Zero point reset status".

CAUTION:

- "Complete" may be displayed if the seat has been reinstalled or "zero point reset" has already been performed.
- "Incomplete" may be displayed if a new seat is installed.
- Air bag warning lamp blinks in user mode if zero point reset is "incomplete".

Is zero point reset status "complete"?

YES >> Print out "Zero point reset current status" screen. Inspection end.

NO >> Recheck the preliminary check items and perform zero point reset again.

CONFIGURATION

CONFIGURATION : Work Procedure

INFOID:000000012159661

1.WRITING MODE SELECTION

CONSULT Configuration

Select "Re/programming, Configuration" of air bag.

When writing saved data>>GO TO 2.

When writing manually>>GO TO 3.

2.PERFORM "AFTER REPLACE ECU" OF "READ / WRITE CONFIGURATION"

A
B
C
D
E
F
G
I
J
K
L
M
N
O
P

SRC

INSPECTION AND ADJUSTMENT

< BASIC INSPECTION >

④CONSULT Configuration

Perform "After Replace ECU" of "Read / Write Configuration".

>> GO TO 4.

3.PERFORM "MANUAL CONFIGURATION"

④CONSULT Configuration

1. Select "Manual Configuration".
2. Touch "Next".
3. Select the "Type ID" searched by using FAST (service parts catalogue) to write the "Type ID" into the air bag diagnosis sensor unit.
4. Touch "OK".
5. Check that the configuration has been successfully written and touch "End".

>> GO TO 4.

4.CHECK ALL ECU SELF DIAGNOSTIC RESULTS

1. Erase all ECU "Self Diagnostic Result" using CONSULT.
2. Turn the ignition switch OFF.
3. Turn the ignition switch ON.
4. Check that all ECU "Self Diagnostic Result" have no DTC.

>> Work End.

INTERMITTENT INCIDENT

< BASIC INSPECTION >

INTERMITTENT INCIDENT

Inspection Procedure

INFOID:000000012159662

INTERMITTENT TROUBLE

An intermittent incident may have occurred in the past but is not being detected currently. This DTC will not be detected on “Self Diagnostic Result [CURRENT]” but may be viewed on “Self Diagnostic Result [PAST]” if the DTC has not been erased.

Trouble Diagnosis with CONSULT

INFOID:000000012159663

CHECK SRS REPAIR HISTORY

Refer to [SRC-16, "SRS History Check"](#).

- A
- B
- C
- D
- E
- F
- G
- SRC**
- I
- J
- K
- L
- M
- N
- O
- P

U1000 CAN COMM CIRCUIT

< DTC/CIRCUIT DIAGNOSIS >

DTC/CIRCUIT DIAGNOSIS

U1000 CAN COMM CIRCUIT

Description

INFOID:000000012159664

CAN (Controller Area Network) is a serial communication system for real-time application. It is an on-vehicle multiplex communication system with high data communication speed and excellent error detection ability. Many electronic control units are equipped into vehicles, and each control unit shares information and links with other control units during operation. With CAN communication, control units are connected with two communication lines (CAN-H line, CAN-L line), allowing a high rate of information transmission with less wiring. Each control unit transmits and receives data but selectively reads required data only. Refer to [LAN-32, "CAN COMMUNICATION SYSTEM : CAN Communication Signal Chart"](#).

DTC Logic

INFOID:000000012159665

DTC DETECTION LOGIC

DTC	CONSULT name	DTC detecting condition	
U1000-01	CAN COMM CIRCUIT	Diagnosis condition	When ignition switch is ON.
		Signal (terminal)	—
		Threshold	—
		Diagnosis delay time	—

POSSIBLE CAUSE

CAN communication system

FAIL-SAFE

—

DTC CONFIRMATION PROCEDURE

1. PERFORM SELF DIAGNOSTIC RESULT

CONSULT

1. Turn ignition switch ON and wait for 7 seconds or more.
2. Select "Self Diagnostic Result" mode of "AIR BAG".
3. Check DTC.

Is DTC detected?

YES >> Refer to [SRC-42, "Diagnosis Procedure"](#).

NO >> Refer to [GI-41, "Intermittent Incident"](#).

Diagnosis Procedure

INFOID:000000012159666

1. CHECK CAN COMMUNICATION SYSTEM

Check CAN communication system. Refer to [LAN-17, "Trouble Diagnosis Flow Chart"](#).

>> Inspection End.

U1010 CONTROL UNIT (CAN)

< DTC/CIRCUIT DIAGNOSIS >

U1010 CONTROL UNIT (CAN)

Description

INFOID:000000012159667

Air bag diagnosis sensor unit performs self-tests at key ON. If CAN communication failure within control unit is detected, DTC is set.

DTC Logic

INFOID:000000012159668

DTC DETECTION LOGIC

DTC	CONSULT screen items (Trouble diagnosis content)	DTC detecting condition	
		Diagnosis condition	When ignition switch is ON.
U1010	CONTROL UNIT (CAN)	Signal (terminal)	—
		Threshold	—
		Diagnosis delay time	—

POSSIBLE CAUSE

Air bag diagnosis sensor unit

FAIL-SAFE

—

DTC CONFIRMATION PROCEDURE

1. PERFORM SELF DIAGNOSTIC RESULT

Ⓜ CONSULT

1. Turn ignition switch ON.
2. Select "Self Diagnostic Result" mode of "AIR BAG".
3. Check DTC.

Is DTC detected?

YES >> Refer to [SRC-43, "Diagnosis Procedure"](#).

NO >> Inspection End.

Diagnosis Procedure

INFOID:000000012159669

1. REPLACE AIR BAG DIAGNOSIS SENSOR UNIT

Replace air bag diagnosis sensor unit. Refer to [SR-30, "Removal and Installation"](#).

>> Inspection End.

B0001 DRIVER AIRBAG MODULE

< DTC/CIRCUIT DIAGNOSIS >

B0001 DRIVER AIRBAG MODULE

DTC Description

INFOID:000000012159670

DTC DETECTION LOGIC

DTC	CONSULT name	DTC detecting condition		
B0001	DRIVER AIRBAG MODULE [OPEN]	13	Diagnosis condition	When ignition switch is ON.
			Signal (terminal)	Driver air bag module circuit (DR1) (terminal 29 and 30)
			Threshold	—
			Diagnosis delay time	—
	DRIVER AIRBAG MODULE [VB-SHORT]	12	Diagnosis condition	When ignition switch is ON.
			Signal (terminal)	Driver air bag module circuit (DR1) (terminal 29 and 30)
			Threshold	—
			Diagnosis delay time	—
	DRIVER AIRBAG MODULE [GND-SHORT]	11	Diagnosis condition	When ignition switch is ON.
			Signal (terminal)	Driver air bag module circuit (DR1) (terminal 29 and 30)
			Threshold	—
			Diagnosis delay time	—
	DRIVER AIRBAG MODULE [SHORT]	00	Diagnosis condition	When ignition switch is ON.
			Signal (terminal)	Driver air bag module circuit (DR1) (terminal 29 and 30)
			Threshold	—
			Diagnosis delay time	—

POSSIBLE CAUSE

[OPEN]

- Connection malfunction or open circuit of harness and connector
- Internal malfunction of driver air bag module
- Internal malfunction of air bag diagnosis sensor unit

[VB-SHORT]

- Connection malfunction or short circuit to power supply of harness and connector
- Internal malfunction of driver air bag module
- Internal malfunction of air bag diagnosis sensor unit

[GND-SHORT]

- Connection malfunction or short circuit to ground of harness and connector
- Internal malfunction of driver air bag module
- Internal malfunction of air bag diagnosis sensor unit

[SHORT]

- Connection malfunction or short circuit of harness and connector
- Internal malfunction of driver air bag module
- Internal malfunction of air bag diagnosis sensor unit

FAIL-SAFE

—

B0001 DRIVER AIRBAG MODULE

< DTC/CIRCUIT DIAGNOSIS >

DTC CONFIRMATION PROCEDURE (With CONSULT)

1. CHECK SELF DIAGNOSTIC RESULT

CONSULT

1. Turn ignition switch ON.
2. Select "Self Diagnostic Result" mode of "AIR BAG"
3. Check DTC.

Is the DTC detected?

YES (Current DTC)>>Refer to [SRC-45, "Diagnosis Procedure"](#).

YES (Past DTC)>>GO TO 2.

NO >> Inspection End.

2. ERASE SELF DIAGNOSTIC RESULT

CONSULT

Erase the DTC.

Can the DTC be erased?

YES >> Inspection End.

NO >> Refer to [SRC-45, "Diagnosis Procedure"](#).

DTC CONFIRMATION PROCEDURE (Without CONSULT)

1. CHECK SELF DIAGNOSTIC RESULT

1. Turn ignition switch ON.
2. Check the air bag warning lamp status. Refer to [SRC-15, "SRS Operation Check"](#).

NOTE:

SRS will not enter diagnosis mode if no malfunction is detected in user mode.

Is the DTC detected?

YES >> Refer to [SRC-45, "Diagnosis Procedure"](#).

NO >> Inspection End.

Diagnosis Procedure

INFOID:0000000012159671

1. HARNESS CONNECTOR

Visually inspect all applicable harness connectors for the following:

- Visible damage to connector or terminal
- Loose terminal
- Poor connection

NOTE:

All harness connectors should be inspected from the air bag diagnosis sensor unit to the end component (including any in-line connectors).

Is the inspection result normal?

YES >> GO TO 2.

- NO >> Perform one of the following repairs:
- Visible damage: Replace the harness.
 - Loose terminal: Secure the terminal.
 - Poor connection: Secure the connection.

2. CONFIRM DTC

CONSULT

1. Reconnect all harness connectors.
2. Turn ignition switch ON.
3. Check DTC.

Is DTC still current?

YES >> GO TO 3.

NO >> Refer to [GI-41, "Intermittent Incident"](#).

3. WIRING HARNESS

Check the wiring harness for visible damage.

A

B

C

D

E

F

G

SRC

I

J

K

L

M

N

O

P

B0001 DRIVER AIRBAG MODULE

< DTC/CIRCUIT DIAGNOSIS >

NOTE:

The entire wiring harness should be inspected from the air bag diagnosis sensor unit to the end component (including any in-line connectors).

Is the inspection result normal?

YES >> GO TO 4.

NO >> Replace the harness.

4. CHECK SPIRAL CABLE CIRCUIT

1. Turn ignition switch OFF.
2. Disconnect driver air bag module harness connectors and spiral cable harness connector.
3. Check continuity between driver air bag module harness connector and spiral cable connector.

Driver air bag module		Spiral cable		Continuity
Connector	Terminal	Connector	Terminal	
M89	23	M29	4	Yes
	24		6	

4. Check continuity between driver air bag module harness connector and ground.

Driver air bag module		Ground	Continuity
Connector	Terminal		
M89	23		No
	24		

Is the inspection result normal?

YES >> GO TO 5.

NO >> Replace the spiral cable. Refer to [SR-16. "Removal and Installation"](#).

5. CONFIRM DTC

1. Reconnect all harness connectors.
2. Turn ignition switch ON.
3. Check for DTC using CONSULT.

Is DTC still current?

YES >> GO TO 6.

NO >> Refer to [GI-41. "Intermittent Incident"](#).

6. AIR BAG DIAGNOSIS SENSOR UNIT

CONSULT

1. Replace the air bag diagnosis sensor unit. Refer to [SR-30. "Removal and Installation"](#).
2. Turn ignition switch ON.
3. Check DTC.

Is DTC still current?

YES >> GO TO 7.

NO >> Clear DTC. Inspection End.

7. DRIVER AIR BAG MODULE

CONSULT

1. Replace the driver air bag module. Refer to [SR-12. "Removal and Installation"](#).
2. Turn ignition switch ON.
3. Check DTC.

Is DTC still current?

YES >> GO TO 8.

NO >> Clear DTC. Inspection End.

8. RELATED HARNESS

Replace the related harness.

B0001 DRIVER AIRBAG MODULE

< DTC/CIRCUIT DIAGNOSIS >

>> Inspection End.

A

B

C

D

E

F

G

SRC

I

J

K

L

M

N

O

P

B0010, B0011 PASSENGER AIRBAG MODULE

< DTC/CIRCUIT DIAGNOSIS >

B0010, B0011 PASSENGER AIRBAG MODULE

DTC Description

INFOID:000000012159672

DTC DETECTION LOGIC

DTC	CONSULT name	DTC detecting condition		
B0010	ASSIST AIRBAG MODULE [OPEN]	13	Diagnosis condition	When ignition switch is ON
			Signal (terminal)	Front passenger air bag module circuit (AS1) (terminal 25 and 26)
			Threshold	—
			Diagnosis delay time	—
	ASSIST AIRBAG MODULE [VB-SHORT]	12	Diagnosis condition	When ignition switch is ON
			Signal (terminal)	Front passenger air bag module circuit (AS1) (terminal 25 and 26)
			Threshold	—
			Diagnosis delay time	—
	ASSIST AIRBAG MODULE [GND-SHORT]	11	Diagnosis condition	When ignition switch is ON
			Signal (terminal)	Front passenger air bag module circuit (AS1) (terminal 25 and 26)
			Threshold	—
			Diagnosis delay time	—
ASSIST AIRBAG MODULE [SHORT]	09	Diagnosis condition	When ignition switch is ON	
		Signal (terminal)	Front passenger air bag module circuit (AS1) (terminal 25 and 26)	
		Threshold	—	
		Diagnosis delay time	—	
B0011	ASSIST AIRBAG MODULE 2ND [OPEN]	13	Diagnosis condition	When ignition switch is ON
			Signal (terminal)	Front passenger air bag module circuit (AS2) (terminal 23 and 24)
			Threshold	—
			Diagnosis delay time	—
	ASSIST AIRBAG MODULE 2ND [VB-SHORT]	12	Diagnosis condition	When ignition switch is ON
			Signal (terminal)	Front passenger air bag module circuit (AS2) (terminal 23 and 24)
			Threshold	—
			Diagnosis delay time	—
	ASSIST AIRBAG MODULE 2ND [GND-SHORT]	11	Diagnosis condition	When ignition switch is ON
			Signal (terminal)	Front passenger air bag module circuit (AS2) (terminal 23 and 24)
			Threshold	—
			Diagnosis delay time	—
ASSIST AIRBAG MODULE 2ND [SHORT]	09	Diagnosis condition	When ignition switch is ON	
		Signal (terminal)	Front passenger air bag module circuit (AS2) (terminal 23 and 24)	
		Threshold	—	
		Diagnosis delay time	—	

POSSIBLE CAUSE

B0010, B0011 PASSENGER AIRBAG MODULE

< DTC/CIRCUIT DIAGNOSIS >

[OPEN]

- Connection malfunction or open circuit of harness and connector
- Internal malfunction of passenger air bag module
- Internal malfunction of air bag diagnosis sensor unit

A

[VB-SHORT]

- Connection malfunction or short circuit to power supply of harness and connector
- Internal malfunction of passenger air bag module
- Internal malfunction of air bag diagnosis sensor unit

B

C

[GND-SHORT]

- Connection malfunction or short circuit to ground of harness and connector
- Internal malfunction of passenger air bag module
- Internal malfunction of air bag diagnosis sensor unit

D

E

[SHORT]

- Connection malfunction or short circuit of harness and connector
- Internal malfunction of passenger air bag module
- Internal malfunction of air bag diagnosis sensor unit

F

FAIL-SAFE

—

G

DTC CONFIRMATION PROCEDURE (With CONSULT)

1. CHECK SELF DIAGNOSTIC RESULT

Ⓜ CONSULT

1. Turn ignition switch ON.
2. Check DTC.

Is the DTC detected?

YES (Current DTC)>> Refer to [SRC-49. "Diagnosis Procedure"](#).

YES (Past DTC)>> GO TO 2.

NO >> Inspection End.

2. ERASE SELF DIAGNOSTIC RESULT

Ⓜ CONSULT

Erase DTC.

Can the DTC be erased?

YES >> Inspection End.

NO >> Refer to [SRC-49. "Diagnosis Procedure"](#).

DTC CONFIRMATION PROCEDURE (Without CONSULT)

1. CHECK SELF DIAGNOSTIC RESULT

1. Turn ignition switch ON.
2. Check the air bag warning lamp status. Refer to [SRC-15. "SRS Operation Check"](#).

NOTE:

SRS will not enter diagnosis mode if no malfunction is detected in user mode.

Is the DTC detected?

YES >> Refer to [SRC-49. "Diagnosis Procedure"](#).

NO >> Inspection End.

Diagnosis Procedure

INFOID:000000012159673

1. HARNESS CONNECTOR

Visually inspect all applicable harness connectors for the following:

- Visible damage to connector or terminal
- Loose terminal
- Poor connection

B0010, B0011 PASSENGER AIRBAG MODULE

< DTC/CIRCUIT DIAGNOSIS >

NOTE:

All harness connectors should be inspected from the air bag diagnosis unit to the end component (including any in-line connectors).

Is the inspection result normal?

YES >> GO TO 2.

- NO >> Perform one of the following repairs:
- Visible damage: Replace the harness.
 - Loose terminal: Secure the terminal.
 - Poor connection: Secure the connection.

2. CONFIRM DTC

1. Reconnect all harness connectors.
2. Turn ignition switch ON.
3. Check for DTC using CONSULT.

Is DTC still current?

YES >> GO TO 3.

NO >> Refer to [GI-41, "Intermittent Incident"](#).

3. WIRING HARNESS

Check the wiring harness for visible damage.

NOTE:

The entire wiring harness should be inspected from the air bag diagnosis sensor unit to the end component (including any in-line connectors).

Is the inspection result normal?

YES >> GO TO 4.

NO >> Replace the harness.

4. CONFIRM DTC

1. Reconnect all harness connectors.
2. Turn ignition switch ON.
3. Check for DTC using CONSULT.

Is DTC still current?

YES >> GO TO 5.

NO >> Refer to [GI-41, "Intermittent Incident"](#).

5. FRONT PASSENGER AIR BAG MODULE

Ⓟ CONSULT

1. Replace the front passenger air bag module. Refer to [SR-19, "Removal and Installation"](#).
2. Turn ignition switch ON.
3. Check DTC.

Is DTC still current?

YES >> GO TO 6.

NO >> Clear DTC. Inspection End.

6. AIR BAG DIAGNOSIS SENSOR UNIT

Ⓟ CONSULT

1. Replace the air bag diagnosis sensor unit. Refer to [SR-30, "Removal and Installation"](#).
2. Turn ignition switch ON.
3. Check DTC.

Is DTC still current?

YES >> GO TO 7.

NO >> Clear DTC. Inspection End.

7. RELATED HARNESS

Replace the related harness.

>> Inspection End.

B0020 SIDE AIRBAG MODULE LH

< DTC/CIRCUIT DIAGNOSIS >

B0020 SIDE AIRBAG MODULE LH

DTC Description

INFOID:000000012159674

DTC DETECTION LOGIC

DTC	CONSULT name	DTC detecting condition		
B0020	SIDE AIRBAG MODULE LH [OPEN]	13	Diagnosis condition	When ignition switch is ON
			Signal (terminal)	Side air bag module LH circuit (terminal 53 and 54)
			Threshold	—
			Diagnosis delay time	—
	SIDE AIRBAG MODULE LH [VB-SHORT]	12	Diagnosis condition	When ignition switch is ON
			Signal (terminal)	Side air bag module LH circuit (terminal 53 and 54)
			Threshold	—
			Diagnosis delay time	—
	SIDE AIRBAG MODULE LH [GND-SHORT]	11	Diagnosis condition	When ignition switch is ON
			Signal (terminal)	Side air bag module LH circuit (terminal 53 and 54)
			Threshold	—
			Diagnosis delay time	—
	SIDE AIRBAG MODULE LH [SHORT]	00	Diagnosis condition	When ignition switch is ON
			Signal (terminal)	Side air bag module LH circuit (terminal 53 and 54)
			Threshold	—
			Diagnosis delay time	—

POSSIBLE CAUSE

[OPEN]

- Connection malfunction or open circuit of harness and connector
- Internal malfunction of side air bag module LH
- Internal malfunction of air bag diagnosis sensor unit

[VB-SHORT]

- Connection malfunction or short circuit to power supply of harness and connector
- Internal malfunction of side air bag module LH
- Internal malfunction of air bag diagnosis sensor unit

[GND-SHORT]

- Connection malfunction or short circuit to ground of harness and connector
- Internal malfunction of side air bag module LH
- Internal malfunction of air bag diagnosis sensor unit

[SHORT]

- Connection malfunction or short circuit of harness and connector
- Internal malfunction of side air bag module LH
- Internal malfunction of air bag diagnosis sensor unit

FAIL-SAFE

—

DTC CONFIRMATION PROCEDURE (With CONSULT)

1. CHECK SELF DIAGNOSTIC RESULT

CONSULT

1. Turn ignition switch ON.
2. Check DTC.

Is the DTC detected?

B0020 SIDE AIRBAG MODULE LH

< DTC/CIRCUIT DIAGNOSIS >

YES (Current DTC)>> Refer to [SRC-52. "Diagnosis Procedure"](#).

YES (Past DTC)>> GO TO 2.

NO >> Inspection End.

2. ERASE SELF DIAGNOSTIC RESULT

CONSULT

Erase DTC.

Can the DTC be erased?

YES >> Inspection End.

NO >> Refer to [SRC-52. "Diagnosis Procedure"](#).

DTC CONFIRMATION PROCEDURE (Without CONSULT)

1. CHECK SELF DIAGNOSTIC RESULT

1. Turn ignition switch ON.

2. Check the air bag warning lamp status. Refer to [SRC-15. "SRS Operation Check"](#).

NOTE:

SRS will not enter diagnosis mode if no malfunction is detected in user mode.

Is the DTC detected?

YES >> Refer to [SRC-52. "Diagnosis Procedure"](#).

NO >> Inspection End.

Diagnosis Procedure

INFOID:0000000012159675

1. HARNESS CONNECTOR

Visually inspect all applicable harness connectors for the following:

- Visible damage to connector or terminal
- Loose terminal
- Poor connection

NOTE:

All harness connectors should be inspected from the air bag diagnosis sensor unit to the end component (including any in-line connectors).

Is the inspection result normal?

YES >> GO TO 2.

NO >> Perform one of the following repairs:

- Visible damage: Replace the harness.
- Loose terminal: Secure the terminal.
- Poor connection: Secure the connection.

2. CONFIRM DTC

CONSULT

1. Reconnect all harness connectors.

2. Turn ignition switch ON.

3. Check DTC.

Is DTC still current?

YES >> GO TO 3.

NO >> Refer to [GI-41. "Intermittent Incident"](#).

3. WIRING HARNESS

Check the wiring harness for visible damage.

NOTE:

The entire wiring harness should be inspected from the air bag diagnosis sensor unit to the end component (including any in-line connectors).

Is the inspection result normal?

YES >> GO TO 4.

NO >> Replace the harness.

4. CONFIRM DTC

B0020 SIDE AIRBAG MODULE LH

< DTC/CIRCUIT DIAGNOSIS >

Ⓜ CONSULT

1. Reconnect all harness connectors.
2. Turn ignition switch ON.
3. Check DTC.

Is DTC still current?

- YES >> GO TO 5.
NO >> Refer to [GI-41, "Intermittent Incident"](#).

5. AIR BAG DIAGNOSIS SENSOR UNIT

Ⓜ CONSULT

1. Replace the air bag diagnosis sensor unit. Refer to [SR-30, "Removal and Installation"](#).
2. Turn ignition switch ON.
3. Check DTC.

Is DTC still current?

- YES >> GO TO 6.
NO >> Clear DTC. Inspection End.

6. SIDE AIR BAG MODULE LH

Ⓜ CONSULT

1. Replace the side air bag module LH. Refer to [SR-24, "Removal and Installation"](#).
2. Turn ignition switch ON.
3. Check DTC.

Is DTC still current?

- YES >> GO TO 7.
NO >> Clear DTC. Inspection End.

7. RELATED HARNESS

Replace the related harness.

>> Inspection End.

A
B
C
D
E
F
G
I
J
K
L
M
N
O
P

SRC

B0028 SIDE AIRBAG MODULE RH

< DTC/CIRCUIT DIAGNOSIS >

B0028 SIDE AIRBAG MODULE RH

DTC Description

INFOID:000000012159676

DTC DETECTION LOGIC

DTC	CONSULT name	DTC detecting condition		
B0028	SIDE AIRBAG MODULE RH [OPEN]	13	Diagnosis condition	When ignition switch is ON
			Signal (terminal)	Side air bag module RH circuit (terminals 3 and 4)
			Threshold	—
			Diagnosis delay time	—
	SIDE AIRBAG MODULE RH [VB-SHORT]	12	Diagnosis condition	When ignition switch is ON
			Signal (terminal)	Side air bag module RH circuit (terminals 3 and 4)
			Threshold	—
			Diagnosis delay time	—
	SIDE AIRBAG MODULE RH [GND-SHORT]	11	Diagnosis condition	When ignition switch is ON
			Signal (terminal)	Side air bag module RH circuit (terminals 3 and 4)
			Threshold	—
			Diagnosis delay time	—
SIDE AIRBAG MODULE RH [SHORT]	09	Diagnosis condition	When ignition switch is ON	
		Signal (terminal)	Side air bag module RH circuit (terminals 3 and 4)	
		Threshold	—	
		Diagnosis delay time	—	

POSSIBLE CAUSE

[OPEN]

- Connection malfunction or open circuit of harness and connector
- Internal malfunction of side air bag module RH
- Internal malfunction of air bag diagnosis sensor unit

[VB-SHORT]

- Connection malfunction or short circuit to power supply of harness and connector
- Internal malfunction of side air bag module RH
- Internal malfunction of air bag diagnosis sensor unit

[GND-SHORT]

- Connection malfunction or short circuit to ground of harness and connector
- Internal malfunction of side air bag module RH
- Internal malfunction of air bag diagnosis sensor unit

[SHORT]

- Connection malfunction or short circuit of harness and connector
- Internal malfunction of side air bag module RH
- Internal malfunction of air bag diagnosis sensor unit

FAIL-SAFE

—

DTC CONFIRMATION PROCEDURE (With CONSULT)

B0028 SIDE AIRBAG MODULE RH

< DTC/CIRCUIT DIAGNOSIS >

1. CHECK SELF DIAGNOSTIC RESULT

CONSULT

1. Turn ignition switch ON.
2. Check DTC.

Is the DTC detected?

YES (Current DTC)>> Refer to [SRC-55, "Diagnosis Procedure"](#).

YES (Past DTC)>> GO TO 2.

NO >> Inspection End.

2. ERASE SELF DIAGNOSTIC RESULT

CONSULT

Erase DTC.

Can the DTC be erased?

YES >> Inspection End.

NO >> Refer to [SRC-55, "Diagnosis Procedure"](#).

DTC CONFIRMATION PROCEDURE (Without CONSULT)

1. CHECK SELF DIAGNOSTIC RESULT

1. Turn ignition switch ON.
2. Check the air bag warning lamp status. Refer to [SRC-15, "SRS Operation Check"](#).

NOTE:

SRS will not enter diagnosis mode if no malfunction is detected in user mode.

Is the DTC detected?

YES >> Refer to [SRC-55, "Diagnosis Procedure"](#).

NO >> Inspection End.

Diagnosis Procedure

INFOID:000000012159677

1. HARNESS CONNECTOR

Visually inspect all applicable harness connectors for the following:

- Visible damage to connector or terminal
- Loose terminal
- Poor connection

NOTE:

All harness connectors should be inspected from the air bag diagnosis sensor unit to the end component (including any in-line connectors).

Is the inspection result normal?

YES >> GO TO 2.

- NO >> Perform one of the following repairs:
- Visible damage: Replace the harness.
 - Loose terminal: Secure the terminal.
 - Poor connection: Secure the connection.

2. CONFIRM DTC

1. Reconnect all harness connectors.
2. Turn ignition switch ON.
3. Check for DTC using CONSULT.

Is DTC still current?

YES >> GO TO 3.

NO >> Refer to [GI-41, "Intermittent Incident"](#).

3. WIRING HARNESS

Check the wiring harness for visible damage.

NOTE:

The entire wiring harness should be inspected from the air bag diagnosis sensor unit to the end component (including any in-line connectors).

B0028 SIDE AIRBAG MODULE RH

< DTC/CIRCUIT DIAGNOSIS >

Is the inspection result normal?

- YES >> GO TO 4.
NO >> Replace the harness.

4. CONFIRM DTC

Ⓟ CONSULT

1. Reconnect all harness connectors.
2. Turn ignition switch ON.
3. Check DTC.

Is DTC still current?

- YES >> GO TO 5.
NO >> Refer to [GI-41, "Intermittent Incident"](#).

5. AIR BAG DIAGNOSIS SENSOR UNIT

Ⓟ CONSULT

1. Replace the air bag diagnosis sensor unit. Refer to [SR-30, "Removal and Installation"](#).
2. Turn ignition switch ON.
3. Check DTC.

Is DTC still current?

- YES >> GO TO 6.
NO >> Clear DTC. Inspection End.

6. SIDE AIR BAG MODULE RH

Ⓟ CONSULT

1. Replace the side air bag module RH.
2. Turn ignition switch ON.
3. Check DTC.

Is DTC still current?

- YES >> GO TO 7.
NO >> Clear DTC. Inspection End.

7. RELATED HARNESS

Replace the related harness.

>> Inspection End.

B0021 SIDE CURTAIN AIR BAG MODULE LH

< DTC/CIRCUIT DIAGNOSIS >

B0021 SIDE CURTAIN AIR BAG MODULE LH

DTC Description

INFOID:000000012159678

DTC DETECTION LOGIC

DTC	CONSULT name	DTC detecting condition		
B0021	CURTAIN AIRBAG MODULE LH CIRCUIT [OPEN]	13	Diagnosis condition	When ignition switch is ON
			Signal (terminal)	LH side curtain air bag module circuit (terminal 55 and 56)
			Threshold	—
			Diagnosis delay time	—
	CURTAIN AIRBAG MODULE LH CIRCUIT [VB-SHORT]	12	Diagnosis condition	When ignition switch is ON
			Signal (terminal)	LH side curtain air bag module circuit (terminal 55 and 56)
			Threshold	—
			Diagnosis delay time	—
	CURTAIN AIRBAG MODULE LH CIRCUIT [GND-SHORT]	11	Diagnosis condition	When ignition switch is ON
			Signal (terminal)	LH side curtain air bag module circuit (terminal 55 and 56)
			Threshold	—
			Diagnosis delay time	—
	CURTAIN AIRBAG MODULE LH CIRCUIT [SHORT]	09	Diagnosis condition	When ignition switch is ON
			Signal (terminal)	LH side curtain air bag module circuit (terminal 55 and 56)
			Threshold	—
			Diagnosis delay time	—

POSSIBLE CAUSE

[OPEN]

- Connection malfunction or open circuit of harness and connector
- Internal malfunction of side curtain air bag module LH
- Internal malfunction of air bag diagnosis sensor unit

[VB-SHORT]

- Connection malfunction or short circuit to power supply of harness and connector
- Internal malfunction of side curtain air bag module LH
- Internal malfunction of air bag diagnosis sensor unit

[GND-SHORT]

- Connection malfunction or short circuit to ground of harness and connector
- Internal malfunction of side curtain air bag module LH
- Internal malfunction of air bag diagnosis sensor unit

[SHORT]

- Connection malfunction or short circuit of harness and connector
- Internal malfunction of side curtain air bag module LH
- Internal malfunction of air bag diagnosis sensor unit

FAIL-SAFE

—

DTC CONFIRMATION PROCEDURE (With CONSULT)

B0021 SIDE CURTAIN AIR BAG MODULE LH

< DTC/CIRCUIT DIAGNOSIS >

1. CHECK SELF DIAGNOSTIC RESULT

CONSULT

1. Turn ignition switch ON.
2. Check DTC.

Is the DTC detected?

YES (Current DTC)>> Refer to [SRC-58, "Diagnosis Procedure"](#).

YES (Past DTC)>> GO TO 2.

NO >> Inspection End.

2. ERASE SELF DIAGNOSTIC RESULT

CONSULT

Erase DTC.

Can the DTC be erased?

YES >> Inspection End.

NO >> Refer to [SRC-58, "Diagnosis Procedure"](#).

DTC CONFIRMATION PROCEDURE (Without CONSULT)

1. CHECK SELF DIAGNOSTIC RESULT

1. Turn ignition switch ON.
2. Check the air bag warning lamp status. Refer to [SRC-15, "SRS Operation Check"](#).

NOTE:

SRS will not enter diagnosis mode if no malfunction is detected in user mode.

Is the DTC detected?

YES >> Refer to [SRC-58, "Diagnosis Procedure"](#).

NO >> Inspection End.

Diagnosis Procedure

INFOID:0000000012159679

1. HARNESS CONNECTOR

Visually inspect all applicable harness connectors for the following:

- Visible damage to connector or terminal
- Loose terminal
- Poor connection

NOTE:

All harness connectors should be inspected from the air bag diagnosis sensor unit to the end component (including any in-line connectors).

Is the inspection result normal?

YES >> GO TO 2.

- NO >> Perform one of the following repairs:
- Visible damage: Replace the harness.
 - Loose terminal: Secure the terminal.
 - Poor connection: Secure the connection.

2. CONFIRM DTC

CONSULT

1. Reconnect all harness connectors.
2. Turn ignition switch ON.
3. Check DTC.

Is DTC still current?

YES >> GO TO 3.

NO >> Refer to [GI-41, "Intermittent Incident"](#).

3. WIRING HARNESS

Check the wiring harness for visible damage.

NOTE:

B0021 SIDE CURTAIN AIR BAG MODULE LH

< DTC/CIRCUIT DIAGNOSIS >

The entire wiring harness should be inspected from the air bag diagnosis sensor unit to the end component (including any in-line connectors).

Is the inspection result normal?

YES >> GO TO 4.

NO >> Replace the harness.

4.CONFIRM DTC

Ⓜ CONSULT

1. Reconnect all harness connectors.
2. Turn ignition switch ON.
3. Check DTC.

Is DTC still current?

YES >> GO TO 5.

NO >> Refer to [GI-41, "Intermittent Incident"](#).

5.AIR BAG DIAGNOSIS SENSOR UNIT

Ⓜ CONSULT

1. Replace the air bag diagnosis sensor unit. Refer to [SR-30, "Removal and Installation"](#).
2. Turn ignition switch ON.
3. Check DTC.

Is DTC still current?

YES >> GO TO 6.

NO >> Clear DTC. Inspection End.

6.SIDE CURTAIN AIR BAG MODULE LH

Ⓜ CONSULT

1. Replace the side curtain air bag module LH. Refer to [SR-24, "Removal and Installation"](#).
2. Turn ignition switch ON.
3. Check DTC.

Is DTC still current?

YES >> GO TO 7.

NO >> Clear DTC. Inspection End.

7.RELATED HARNESS

Replace the related harness.

>> Inspection End.

A
B
C
D
E
F
G
I
J
K
L
M
N
O
P

SRC

B0029 SIDE CURTAIN AIR BAG MODULE RH

< DTC/CIRCUIT DIAGNOSIS >

B0029 SIDE CURTAIN AIR BAG MODULE RH

DTC Description

INFOID:000000012159680

DTC DETECTION LOGIC

DTC	CONSULT name	DTC detecting condition		
B0029	CURTAIN AIRBAG MODULE RH [OPEN]	13	Diagnosis condition	When the ignition switch is ON
			Signal (terminal)	RH side curtain air bag module circuit (terminal 5 and 6)
			Threshold	—
			Diagnosis delay time	—
B0029	CURTAIN AIRBAG MODULE RH [VB-SHORT]	12	Diagnosis condition	When the ignition switch is ON
			Signal (terminal)	RH side curtain air bag module circuit (terminal 5 and 6)
			Threshold	—
			Diagnosis delay time	—
B0029	CURTAIN AIRBAG MODULE RH [GND-SHORT]	11	Diagnosis condition	When the ignition switch is ON
			Signal (terminal)	RH side curtain air bag module circuit (terminal 5 and 6)
			Threshold	—
			Diagnosis delay time	—
B0029	CURTAIN AIRBAG MODULE RH [SHORT]	09	Diagnosis condition	When the ignition switch is ON
			Signal (terminal)	RH side curtain air bag module circuit (terminal 5 and 6)
			Threshold	—
			Diagnosis delay time	—

POSSIBLE CAUSE

[OPEN]

- Connection malfunction or open circuit of harness and connector
- Internal malfunction of curtain air bag module RH
- Internal malfunction of air bag diagnosis sensor unit

[VB-SHORT]

- Connection malfunction or short circuit to power supply of harness and connector
- Internal malfunction of curtain air bag module RH
- Internal malfunction of air bag diagnosis sensor unit

[GND-SHORT]

- Connection malfunction or short circuit to ground of harness and connector
- Internal malfunction of curtain air bag module RH
- Internal malfunction of air bag diagnosis sensor unit

[SHORT]

- Connection malfunction or short circuit of harness and connector
- Internal malfunction of curtain air bag module RH
- Internal malfunction of air bag diagnosis sensor unit

DTC CONFIRMATION PROCEDURE (With CONSULT)

B0029 SIDE CURTAIN AIR BAG MODULE RH

< DTC/CIRCUIT DIAGNOSIS >

1. CHECK SELF DIAGNOSTIC RESULT

CONSULT

1. Turn ignition switch ON.
2. Check for DTC using CONSULT.

Is the DTC detected?

YES (Current DTC)>> Refer to [SRC-61, "Diagnosis Procedure"](#).

YES (Past DTC)>> GO TO 2.

NO >> Inspection End.

2. ERASE SELF DIAGNOSTIC RESULT

CONSULT

Erase DTC.

Can the DTC be erased?

YES >> Inspection End.

NO >> Refer to [SRC-61, "Diagnosis Procedure"](#).

DTC CONFIRMATION PROCEDURE (Without CONSULT)

1. CHECK SELF DIAGNOSTIC RESULT

1. Turn ignition switch ON.
2. Check the air bag warning lamp status. Refer to [SRC-15, "SRS Operation Check"](#).

NOTE:

SRS will not enter diagnosis mode if no malfunction is detected in user mode.

Is the DTC detected?

YES >> Refer to [SRC-61, "Diagnosis Procedure"](#).

NO >> Inspection End.

Diagnosis Procedure

INFOID:000000012159681

1. HARNESS CONNECTOR

Visually inspect all applicable harness connectors for the following:

- Visible damage to connector or terminal
- Loose terminal
- Poor connection

NOTE:

All harness connectors should be inspected from the air bag diagnosis sensor unit to the end component (including any in-line connectors).

Is the inspection result normal?

YES >> GO TO 2.

- NO >> Perform one of the following repairs:
- Visible damage: Replace the harness.
 - Loose terminal: Secure the terminal.
 - Poor connection: Secure the connection.

2. CONFIRM DTC

CONSULT

1. Reconnect all harness connectors.
2. Turn ignition switch ON.
3. Check DTC

Is DTC still current?

YES >> GO TO 3.

NO >> Refer to [GI-41, "Intermittent Incident"](#).

3. WIRING HARNESS

Check the wiring harness for visible damage.

NOTE:

B0029 SIDE CURTAIN AIR BAG MODULE RH

< DTC/CIRCUIT DIAGNOSIS >

The entire wiring harness should be inspected from the air bag diagnosis sensor unit to the end component (including any in-line connectors).

Is the inspection result normal?

YES >> GO TO 4.

NO >> Replace the harness.

4.CONFIRM DTC

Ⓟ CONSULT

1. Reconnect all harness connectors.
2. Turn ignition switch ON.
3. Check DTC.

Is DTC still current?

YES >> GO TO 5.

NO >> Refer to [GI-41, "Intermittent Incident"](#).

5.AIR BAG DIAGNOSIS SENSOR UNIT

Ⓟ CONSULT

1. Replace the air bag diagnosis sensor unit. Refer to [SR-30, "Removal and Installation"](#).
2. Turn ignition switch ON.
3. Check DTC.

Is DTC still current?

YES >> GO TO 6.

NO >> Clear DTC. Inspection End.

6.SIDE CURTAIN AIR BAG MODULE RH

Ⓟ CONSULT

1. Replace the side curtain air bag module RH. Refer to [SR-22, "Removal and Installation"](#).
2. Turn ignition switch ON.
3. Check DTC.

Is DTC still current?

YES >> GO TO 7.

NO >> Clear DTC. Inspection End.

7.RELATED HARNESS

Replace the related harness.

>> Inspection End.

B0094 CRASH ZONE SENSOR

< DTC/CIRCUIT DIAGNOSIS >

B0094 CRASH ZONE SENSOR

DTC Description

INFOID:000000012159682

DTC DETECTION LOGIC

DTC	CONSULT name	DTC detecting condition		
B0094	CRASH ZONE SENSOR [RESET]	93	Diagnosis condition	When ignition switch is ON.
			Signal (terminal)	Crash zone sensor (terminal 31 and 41)
			Threshold	—
			Diagnosis delay time	—
	CRASH ZONE SENSOR [COMM ERR]	81	Diagnosis condition	When ignition switch is ON.
			Signal (terminal)	Crash zone sensor (terminal 31 and 41)
			Threshold	—
			Diagnosis delay time	—
	CRASH ZONE SENSOR [OPEN]	88	Diagnosis condition	When ignition switch is ON.
			Signal (terminal)	Crash zone sensor (terminal 31 and 41)
			Threshold	—
			Diagnosis delay time	—
	CRASH ZONE SENSOR [UNMATCH]	86	Diagnosis condition	When ignition switch is ON.
			Signal (terminal)	Crash zone sensor (terminal 31 and 41)
			Threshold	—
			Diagnosis delay time	—
	CRASH ZONE SENSOR [OFFSET ERR]	28	Diagnosis condition	When ignition switch is ON.
			Signal (terminal)	Crash zone sensor (terminal 31 and 41)
			Threshold	—
			Diagnosis delay time	—
	CRASH ZONE SENSOR [SELF-DIAG ERR]	25	Diagnosis condition	When ignition switch is ON.
			Signal (terminal)	Crash zone sensor (terminal 31 and 41)
			Threshold	—
			Diagnosis delay time	—
	CRASH ZONE SENSOR [LOWER LIMIT ERR]	23	Diagnosis condition	When ignition switch is ON.
			Signal (terminal)	Crash zone sensor (terminal 31 and 41)
			Threshold	—
			Diagnosis delay time	—
CRASH ZONE SENSOR [UPPER LIMIT ERR]	24	Diagnosis condition	When ignition switch is ON.	
		Signal (terminal)	Crash zone sensor (terminal 31 and 41)	
		Threshold	—	
		Diagnosis delay time	—	
CRASH ZONE SENSOR [GND-SHORT]	11	Diagnosis condition	When ignition switch is ON.	
		Signal (terminal)	Crash zone sensor (terminal 31 and 41)	
		Threshold	—	
		Diagnosis delay time	—	

POSSIBLE CAUSE

[RESET], [COMM ERR]

- Connection malfunction of harness or connector

B0094 CRASH ZONE SENSOR

< DTC/CIRCUIT DIAGNOSIS >

- Internal malfunction of crash zone sensor
- Internal malfunction of air bag diagnosis sensor unit

[OPEN]

- Connection malfunction or open circuit of harness or connector
- Internal malfunction of crash zone sensor
- Internal malfunction of air bag diagnosis sensor unit

[UNMATCH]

- Air bag diagnosis sensor unit and crash zone sensor is different from the part specified

[OFFSET ERR], [SELF-DIAG ERR], [LOWER LIMIT ERR], [UPPER LIMIT ERR]

- Internal malfunction of crash zone sensor
- Internal malfunction of air bag diagnosis sensor unit

[GND-SHORT]

- Connection malfunction or short circuit to ground of harness or connector
- Internal malfunction of crash zone sensor
- Internal malfunction of air bag diagnosis sensor unit

FAIL-SAFE

—

DTC CONFIRMATION PROCEDURE (With CONSULT)

1. CHECK SELF DIAGNOSTIC RESULT

Ⓟ CONSULT

1. Turn ignition switch ON.
2. Check DTC.

Is the DTC detected?

YES (Current DTC)>> Refer to [SRC-64, "Diagnosis Procedure"](#).

YES (Past DTC)>> GO TO 2.

NO >> Inspection End.

2. ERASE SELF DIAGNOSTIC RESULT

Ⓟ CONSULT

Erase DTC.

Can the DTC be erased?

YES >> Inspection End.

NO >> Refer to [SRC-64, "Diagnosis Procedure"](#).

DTC CONFIRMATION PROCEDURE (Without CONSULT)

1. CHECK SELF DIAGNOSTIC RESULT

1. Turn ignition switch ON.
2. Check the air bag warning lamp status. Refer to [SRC-15, "SRS Operation Check"](#).

NOTE:

SRS will not enter diagnosis mode if no malfunction is detected in user mode.

Is the DTC detected?

YES >> Refer to [SRC-64, "Diagnosis Procedure"](#).

NO >> Inspection End.

Diagnosis Procedure

INFOID:000000012159683

1. HARNESS CONNECTOR

Visually inspect all applicable harness connectors for the following:

- Visible damage to connector or terminal

B0094 CRASH ZONE SENSOR

< DTC/CIRCUIT DIAGNOSIS >

- Loose terminal
- Poor connection

A

NOTE:

All harness connectors should be inspected from the air bag diagnosis sensor unit to the end component (including any in-line connectors).

B

Is the inspection result normal?

YES >> GO TO 2.

NO >> Perform one of the following repairs:

- Visible damage: Replace the harness.
- Loose terminal: Secure the terminal.
- Poor connection: Secure the connection.

C

2. CONFIRM DTC

D

Ⓜ CONSULT

1. Reconnect all harness connectors.
2. Turn ignition switch ON.
3. Check DTC.

E

Is DTC still current?

YES >> GO TO 3.

NO >> Refer to [GI-41, "Intermittent Incident"](#).

F

3. WIRING HARNESS

G

Check the wiring harness for visible damage.

NOTE:

The entire wiring harness should be inspected from the air bag diagnosis sensor unit to the end component (including any in-line connectors).

SRC

Is the inspection result normal?

YES >> GO TO 4.

NO >> Replace the harness.

I

4. CONFIRM DTC

J

Ⓜ CONSULT

1. Reconnect all harness connectors.
2. Turn ignition switch ON.
3. Check DTC.

K

Is DTC still current?

YES >> GO TO 5.

NO >> Refer to [GI-41, "Intermittent Incident"](#).

L

5. CRASH ZONE SENSOR

M

Ⓜ CONSULT

1. Replace the crash zone sensor. Refer to [SR-25, "Removal and Installation"](#).
2. Turn ignition switch ON.
3. Check DTC.

N

Is DTC still current?

YES >> GO TO 6.

NO >> Clear DTC. Inspection End.

O

6. AIR BAG DIAGNOSIS SENSOR UNIT

Ⓜ CONSULT

1. Replace the air bag diagnosis sensor unit. Refer to [SR-30, "Removal and Installation"](#).
2. Turn ignition switch ON.
3. Check DTC.

P

Is DTC still current?

YES >> GO TO 7.

NO >> Clear DTC. Inspection End.

7. RELATED HARNESS

B0094 CRASH ZONE SENSOR

< DTC/CIRCUIT DIAGNOSIS >

Replace the related harness.

>> Inspection End.

B0091 FRONT SIDE AIR BAG SATELLITE SENSOR LH

< DTC/CIRCUIT DIAGNOSIS >

B0091 FRONT SIDE AIR BAG SATELLITE SENSOR LH

DTC Description

INFOID:000000012159684

DTC DETECTION LOGIC

A

B

C

D

E

F

G

SRC

I

J

K

L

M

N

O

P

B0091 FRONT SIDE AIR BAG SATELLITE SENSOR LH

< DTC/CIRCUIT DIAGNOSIS >

DTC	CONSULT name	DTC detecting condition		
B0091	B-PILLAR SAT SEN LH [RESET]	93	Diagnosis condition	When ignition switch is ON.
			Signal (terminal)	Front side air bag satellite sensor LH (terminals 68 and 69)
			Threshold	—
			Diagnosis delay time	—
	B-PILLAR SAT SEN LH [COMM ERR]	81	Diagnosis condition	When ignition switch is ON.
			Signal (terminal)	Front side air bag satellite sensor LH (terminals 68 and 69)
			Threshold	—
			Diagnosis delay time	—
	B-PILLAR SAT SEN LH [OPEN]	88	Diagnosis condition	When ignition switch is ON.
			Signal (terminal)	Front side air bag satellite sensor LH (terminals 68 and 69)
			Threshold	—
			Diagnosis delay time	—
	B-PILLAR SAT SEN LH [UNMATCH]	86	Diagnosis condition	When ignition switch is ON.
			Signal (terminal)	Front side air bag satellite sensor LH (terminals 68 and 69)
			Threshold	—
			Diagnosis delay time	—
	B-PILLAR SAT SEN LH [OFFSET ERR]	28	Diagnosis condition	When ignition switch is ON.
			Signal (terminal)	Front side air bag satellite sensor LH (terminals 68 and 69)
			Threshold	—
			Diagnosis delay time	—
	B-PILLAR SAT SEN LH [SELF-DIAG ERR]	25	Diagnosis condition	When ignition switch is ON.
			Signal (terminal)	Front side air bag satellite sensor LH (terminals 68 and 69)
			Threshold	—
			Diagnosis delay time	—
	B-PILLAR SAT SEN LH [LOWER LIMIT ERR]	23	Diagnosis condition	When ignition switch is ON.
			Signal (terminal)	Front side air bag satellite sensor LH (terminals 68 and 69)
			Threshold	—
			Diagnosis delay time	—
B-PILLAR SAT SEN LH [UPPER LIMIT ERR]	24	Diagnosis condition	When ignition switch is ON.	
		Signal (terminal)	Front side air bag satellite sensor LH (terminals 68 and 69)	
		Threshold	—	
		Diagnosis delay time	—	
B-PILLAR SAT SEN LH [GND-SHORT]	11	Diagnosis condition	When ignition switch is ON.	
		Signal (terminal)	Front side air bag satellite sensor LH (terminals 68 and 69)	
		Threshold	—	
		Diagnosis delay time	—	

B0091 FRONT SIDE AIR BAG SATELLITE SENSOR LH

< DTC/CIRCUIT DIAGNOSIS >

POSSIBLE CAUSE

[RESET], [COMM ERR]

- Connection malfunction of harness or connector
- Internal malfunction of B-pillar satellite sensor LH
- Internal malfunction of air bag diagnosis sensor unit

[OPEN]

- Connection malfunction or open circuit of harness or connector
- Internal malfunction of B-pillar satellite sensor LH
- Internal malfunction of air bag diagnosis sensor unit

[UNMATCH]

- Air bag diagnosis sensor unit and B-pillar satellite sensor LH is different from part specified

[OFFSET ERR], [SELF-DIAG ERR], [LOWER LIMIT ERR], [UPPER LIMIT ERR]

- Internal malfunction of B-pillar satellite sensor LH
- Internal malfunction of air bag diagnosis sensor unit

[GND-SHORT]

- Connection malfunction or short circuit to ground of harness or connector
- Internal malfunction of B-pillar satellite sensor LH
- Internal malfunction of air bag diagnosis sensor unit

FAIL-SAFE

—

DTC CONFIRMATION PROCEDURE (With CONSULT)

1.CHECK SELF DIAGNOSTIC RESULT

Ⓜ CONSULT

1. Turn ignition switch ON.
2. Check DTC.

Is the DTC detected?

YES (Current DTC)>> Refer to [SRC-69, "Diagnosis Procedure"](#).

YES (Past DTC)>> GO TO 2.

NO >> Inspection End.

2.ERASE SELF DIAGNOSTIC RESULT

Ⓜ CONSULT

Erase DTC.

Can the DTC be erased?

YES >> Inspection End.

NO >> Refer to [SRC-69, "Diagnosis Procedure"](#).

DTC CONFIRMATION PROCEDURE (Without CONSULT)

1.CHECK SELF DIAGNOSTIC RESULT

1. Turn ignition switch ON.
2. Check the air bag warning lamp status. Refer to [SRC-15, "SRS Operation Check"](#).

NOTE:

SRS will not enter diagnosis mode if no malfunction is detected in user mode.

Is the DTC detected?

YES >> Refer to [SRC-69, "Diagnosis Procedure"](#).

NO >> Inspection End.

Diagnosis Procedure

INFOID:000000012159685

1.HARNES CONNECTOR

B0091 FRONT SIDE AIR BAG SATELLITE SENSOR LH

< DTC/CIRCUIT DIAGNOSIS >

Visually inspect all applicable harness connectors for the following:

- Visible damage to connector or terminal
- Loose terminal
- Poor connection

NOTE:

All harness connectors should be inspected from the air bag diagnosis sensor unit to the end component (including any in-line connectors).

Is the inspection result normal?

YES >> GO TO 2.

- NO >> Perform one of the following repairs:
- Visible damage: Replace the harness.
 - Loose terminal: Secure the terminal.
 - Poor connection: Secure the connection.

2. CONFIRM DTC

Ⓟ CONSULT

1. Reconnect all harness connectors.
2. Turn ignition switch ON.
3. Check DTC.

Is DTC still current?

YES >> GO TO 3.

NO >> Refer to [GI-41, "Intermittent Incident"](#).

3. WIRING HARNESS

Check the wiring harness for visible damage.

NOTE:

The entire wiring harness should be inspected from the air bag diagnosis sensor unit to the end component (including any in-line connectors).

Is the inspection result normal?

YES >> GO TO 4.

NO >> Replace the harness.

4. CONFIRM DTC

Ⓟ CONSULT

1. Reconnect all harness connectors.
2. Turn ignition switch ON.
3. Check DTC.

Is DTC still current?

YES >> GO TO 5.

NO >> Refer to [GI-41, "Intermittent Incident"](#).

5. FRONT SIDE AIR BAG SATELLITE SENSOR LH

Ⓟ CONSULT

1. Replace the front side air bag satellite sensor LH. Refer to [SR-27, "Removal and Installation"](#).
2. Turn ignition switch ON.
3. Check DTC.

Is DTC still current?

YES >> GO TO 6.

NO >> Clear DTC. Inspection End.

6. AIR BAG DIAGNOSIS SENSOR UNIT

Ⓟ CONSULT

1. Replace the air bag diagnosis sensor unit. Refer to [SR-30, "Removal and Installation"](#).
2. Turn ignition switch ON.
3. Check DTC.

Is DTC still current?

YES >> GO TO 7.

NO >> Clear DTC. Inspection End.

B0091 FRONT SIDE AIR BAG SATELLITE SENSOR LH

< DTC/CIRCUIT DIAGNOSIS >

7.RELATED HARNESS

Replace the related harness.

>> Inspection End.

A

B

C

D

E

F

G

SRC

I

J

K

L

M

N

O

P

B0096 FRONT SIDE AIR BAG SATELLITE SENSOR RH

< DTC/CIRCUIT DIAGNOSIS >

B0096 FRONT SIDE AIR BAG SATELLITE SENSOR RH

DTC Description

INFOID:000000012159686

DTC DETECTION LOGIC

B0096 FRONT SIDE AIR BAG SATELLITE SENSOR RH

< DTC/CIRCUIT DIAGNOSIS >

DTC	CONSULT name	DTC detecting condition		A	
B0096	B-PILLAR SAT SEN RH [RESET]	93	Diagnosis condition	When ignition switch is ON.	B
			Signal (terminal)	Front side air bag satellite sensor LH (terminals 18 and 19)	C
			Threshold	—	D
			Diagnosis delay time	—	E
	B-PILLAR SAT SEN LH [COMM ERR]	81	Diagnosis condition	When ignition switch is ON.	F
			Signal (terminal)	Front side air bag satellite sensor LH (terminals 18 and 19)	G
			Threshold	—	H
			Diagnosis delay time	—	I
	B-PILLAR SAT SEN RH [OPEN]	88	Diagnosis condition	When ignition switch is ON.	J
			Signal (terminal)	Front side air bag satellite sensor LH (terminals 18 and 19)	K
			Threshold	—	L
			Diagnosis delay time	—	M
	B-PILLAR SAT SEN RH [UNMATCH]	86	Diagnosis condition	When ignition switch is ON.	N
			Signal (terminal)	Front side air bag satellite sensor LH (terminals 18 and 19)	O
			Threshold	—	P
			Diagnosis delay time	—	Q
	B-PILLAR SAT SEN RH [OFFSET ERR]	28	Diagnosis condition	When ignition switch is ON.	R
			Signal (terminal)	Front side air bag satellite sensor LH (terminals 18 and 19)	S
			Threshold	—	T
			Diagnosis delay time	—	U
	B-PILLAR SAT SEN RH [SELF-DIAG ERR]	25	Diagnosis condition	When ignition switch is ON.	V
			Signal (terminal)	Front side air bag satellite sensor LH (terminals 18 and 19)	W
			Threshold	—	X
			Diagnosis delay time	—	Y
	B-PILLAR SAT SEN RH [LOWER LIMIT ERR]	23	Diagnosis condition	When ignition switch is ON.	Z
			Signal (terminal)	Front side air bag satellite sensor LH (terminals 18 and 19)	AA
			Threshold	—	AB
			Diagnosis delay time	—	AC
B-PILLAR SAT SEN RH [UPPER LIMIT ERR]	24	Diagnosis condition	When ignition switch is ON.	AD	
		Signal (terminal)	Front side air bag satellite sensor LH (terminals 18 and 19)	AE	
		Threshold	—	AF	
		Diagnosis delay time	—	AG	
B-PILLAR SAT SEN RH [GND-SHORT]	11	Diagnosis condition	When ignition switch is ON.	AH	
		Signal (terminal)	Front side air bag satellite sensor LH (terminals 18 and 19)	AI	
		Threshold	—	AJ	
		Diagnosis delay time	—	AK	

SRC

B0096 FRONT SIDE AIR BAG SATELLITE SENSOR RH

< DTC/CIRCUIT DIAGNOSIS >

POSSIBLE CAUSE

[RESET], [COMM ERR]

- Connection malfunction of harness or connector
- Internal malfunction of front side air bag satellite sensor RH
- Internal malfunction of air bag diagnosis sensor unit

[OPEN]

- Connection malfunction or open circuit of harness or connector
- Internal malfunction of front side air bag satellite sensor RH
- Internal malfunction of air bag diagnosis sensor unit

[UNMATCH]

- Air bag diagnosis sensor unit and front side air bag satellite sensor RH is different from the part specified

[OFFSET ERR], [SELF-DIAG ERR], [LOWER LIMIT ERR], [UPPER LIMIT ERR]

- Internal malfunction of front side air bag satellite sensor RH
- Internal malfunction of air bag diagnosis sensor unit

[OPEN]

- Connection malfunction or short circuit to ground of harness or connector
- Internal malfunction of front side air bag satellite sensor RH
- Internal malfunction of air bag diagnosis sensor unit

FAIL-SAFE

—

DTC CONFIRMATION PROCEDURE (With CONSULT)

1. CHECK SELF DIAGNOSTIC RESULT

Ⓟ CONSULT

1. Turn ignition switch ON.
2. Check DTC.

Is the DTC detected?

YES (Current DTC)>> Refer to [SRC-75. "Diagnosis Procedure"](#).

YES (Past DTC)>> GO TO 2.

NO >> Inspection End.

2. ERASE SELF DIAGNOSTIC RESULT

Ⓟ CONSULT

Erase DTC.

Can the DTC be erased?

YES >> Inspection End.

NO >> Refer to [SRC-75. "Diagnosis Procedure"](#).

DTC CONFIRMATION PROCEDURE (Without CONSULT)

1. CHECK SELF DIAGNOSTIC RESULT

1. Turn ignition switch ON.
2. Check the air bag warning lamp status. Refer to [SRC-15. "SRS Operation Check"](#).

NOTE:

SRS will not enter diagnosis mode if no malfunction is detected in user mode.

Is the DTC detected?

YES >> Refer to [SRC-75. "Diagnosis Procedure"](#).

NO >> Inspection End.

B0096 FRONT SIDE AIR BAG SATELLITE SENSOR RH

< DTC/CIRCUIT DIAGNOSIS >

Diagnosis Procedure

INFOID:000000012159687

1. HARNESS CONNECTOR

Visually inspect all applicable harness connectors for the following:

- Visible damage to connector or terminal
- Loose terminal
- Poor connection

NOTE:

All harness connectors should be inspected from the air bag diagnosis sensor unit to the end component (including any in-line connectors).

Is the inspection result normal?

YES >> GO TO 2.

- NO >> Perform one of the following repairs:
- Visible damage: Replace the harness.
 - Loose terminal: Secure the terminal.
 - Poor connection: Secure the connection.

2. CONFIRM DTC

 CONSULT

1. Reconnect all harness connectors.
2. Turn ignition switch ON.
3. Check DTC.

Is DTC still current?

YES >> GO TO 3.

NO >> Refer to [GI-41, "Intermittent Incident"](#).

3. WIRING HARNESS

Check the wiring harness for visible damage.

NOTE:

The entire wiring harness should be inspected from the air bag diagnosis sensor unit to the end component (including any in-line connectors).

Is the inspection result normal?

YES >> GO TO 4.

NO >> Replace the harness.

4. CONFIRM DTC

 CONSULT

1. Reconnect all harness connectors.
2. Turn ignition switch ON.
3. Check DTC.

Is DTC still current?

YES >> GO TO 5.

NO >> Refer to [GI-41, "Intermittent Incident"](#).

5. FRONT SIDE AIR BAG SATELLITE SENSOR RH

 CONSULT

1. Replace the front side air bag satellite sensor RH. Refer to [SR-27, "Removal and Installation"](#).
2. Turn ignition switch ON.
3. Check DTC.

Is DTC still current?

YES >> GO TO 6.

NO >> Clear DTC. Inspection End.

6. AIR BAG DIAGNOSIS SENSOR UNIT

 CONSULT

1. Replace the air bag diagnosis sensor unit. Refer to [SR-30, "Removal and Installation"](#).
2. Turn ignition switch ON.

A
B
C
D
E
F
G
I
J
K
L
M
N
O
P

SRC

B0096 FRONT SIDE AIR BAG SATELLITE SENSOR RH

< DTC/CIRCUIT DIAGNOSIS >

3. Check DTC.

Is DTC still current?

YES >> GO TO 7.

NO >> Clear DTC. Inspection End.

7.RELATED HARNESS

Replace the related harness.

>> Inspection End.

B0092 REAR SIDE AIR BAG SATELLITE SENSOR LH

< DTC/CIRCUIT DIAGNOSIS >

B0092 REAR SIDE AIR BAG SATELLITE SENSOR LH

DTC Description

INFOID:000000012159688

DTC DETECTION LOGIC

A
B
C
D
E
F
G
I
J
K
L
M
N
O
P

SRC

DTC	CONSULT name	DTC detecting condition		
B0092	C-PILLAR SAT SEN LH [RESET]	93	Diagnosis condition	When ignition switch is ON.
			Signal (terminal)	Rear side air bag satellite sensor LH (terminal 61 and 62)
			Threshold	—
			Diagnosis delay time	—
	C-PILLAR SAT SEN LH [COMM ERR]	81	Diagnosis condition	When ignition switch is ON.
			Signal (terminal)	Rear side air bag satellite sensor LH (terminal 61 and 62)
			Threshold	—
			Diagnosis delay time	—
	C-PILLAR SAT SEN LH [DISCONNECT]	88	Diagnosis condition	When ignition switch is ON.
			Signal (terminal)	Rear side air bag satellite sensor LH (terminal 61 and 62)
			Threshold	—
			Diagnosis delay time	—
	C-PILLAR SAT SEN LH [UNMATCH]	86	Diagnosis condition	When ignition switch is ON.
			Signal (terminal)	Rear side air bag satellite sensor LH (terminal 61 and 62)
			Threshold	—
			Diagnosis delay time	—
	C-PILLAR SAT SEN LH [OFFSET ERR]	28	Diagnosis condition	When ignition switch is ON.
			Signal (terminal)	Rear side air bag satellite sensor LH (terminal 61 and 62)
			Threshold	—
			Diagnosis delay time	—
	C-PILLAR SAT SEN LH [SELF-DIAG ERR]	25	Diagnosis condition	When ignition switch is ON.
			Signal (terminal)	Rear side air bag satellite sensor LH (terminal 61 and 62)
			Threshold	—
			Diagnosis delay time	—
C-PILLAR SAT SEN LH [LOWER LIMIT ERR]	23	Diagnosis condition	When ignition switch is ON.	
		Signal (terminal)	Rear side air bag satellite sensor LH (terminal 61 and 62)	
		Threshold	—	
		Diagnosis delay time	—	
C-PILLAR SAT SEN LH [UPPER LIMIT ERR]	24	Diagnosis condition	When ignition switch is ON.	
		Signal (terminal)	Rear side air bag satellite sensor LH (terminal 61 and 62)	
		Threshold	—	
		Diagnosis delay time	—	

B0092 REAR SIDE AIR BAG SATELLITE SENSOR LH

< DTC/CIRCUIT DIAGNOSIS >

DTC	CONSULT name	DTC detecting condition		
B0092	C-PILLAR SAT SEN LH [GND-SHORT]	11	Diagnosis condition	When ignition switch is ON.
			Signal (terminal)	Rear side air bag satellite sensor LH (terminal 61 and 62)
			Threshold	—
			Diagnosis delay time	—

POSSIBLE CAUSE

[RESET], [COMM ERR]

- Connection malfunction of harness or connector
- Internal malfunction of C-pillar satellite sensor LH
- Internal malfunction of air bag diagnosis sensor unit

[OPEN], [DISCONNECT]

- Connection malfunction or open circuit of harness or connector
- Internal malfunction of C-pillar satellite sensor LH
- Internal malfunction of air bag diagnosis sensor unit

[UNMATCH]

- Air bag diagnosis sensor unit and C-pillar satellite sensor LH is different from the part specified

[OFFSET ERR], [SELF-DIAG ERR], [LOWER LIMIT ERR], [UPPER LIMIT ERR]

- Internal malfunction of C-pillar satellite sensor LH
- Internal malfunction of air bag diagnosis sensor unit

[GND-SHORT]

- Connection malfunction or short circuit to ground of harness or connector
- Internal malfunction of C-pillar satellite sensor LH
- Internal malfunction of air bag diagnosis sensor unit

FAIL-SAFE

—

DTC CONFIRMATION PROCEDURE (With CONSULT)

1. CHECK SELF DIAGNOSTIC RESULT

Ⓟ CONSULT

1. Turn ignition switch ON.
2. Check DTC.

Is the DTC detected?

- YES (Current DTC)>> Refer to [SRC-79, "Diagnosis Procedure"](#).
- YES (Past DTC)>> GO TO 2.
- NO >> Inspection End.

2. ERASE SELF DIAGNOSTIC RESULT

Ⓟ CONSULT

Erase DTC.

Can the DTC be erased?

- YES >> Inspection End.
- NO >> Refer to [SRC-79, "Diagnosis Procedure"](#).

DTC CONFIRMATION PROCEDURE (Without CONSULT)

1. CHECK SELF DIAGNOSTIC RESULT

1. Turn ignition switch ON.

B0092 REAR SIDE AIR BAG SATELLITE SENSOR LH

< DTC/CIRCUIT DIAGNOSIS >

2. Check the air bag warning lamp status. Refer to [SRC-15, "SRS Operation Check"](#).

NOTE:

SRS will not enter diagnosis mode if no malfunction is detected in user mode.

Is the DTC detected?

- YES >> Refer to [SRC-79, "Diagnosis Procedure"](#).
NO >> Inspection End.

Diagnosis Procedure

INFOID:000000012159689

1. HARNESS CONNECTOR

Visually inspect all applicable harness connectors for the following:

- Visible damage to connector or terminal
- Loose terminal
- Poor connection

NOTE:

All harness connectors should be inspected from the air bag diagnosis sensor unit to the end component (including any in-line connectors).

Is the inspection result normal?

- YES >> GO TO 2.
NO >> Perform one of the following repairs:
 - Visible damage: Replace the harness.
 - Loose terminal: Secure the terminal.
 - Poor connection: Secure the connection.

2. CONFIRM DTC

Ⓜ CONSULT

1. Reconnect all harness connectors.
2. Turn ignition switch ON.
3. Check DTC.

Is DTC still current?

- YES >> GO TO 3.
NO >> Refer to [GI-41, "Intermittent Incident"](#).

3. WIRING HARNESS

Check the wiring harness for visible damage.

NOTE:

The entire wiring harness should be inspected from the air bag diagnosis sensor unit to the end component (including any in-line connectors).

Is the inspection result normal?

- YES >> GO TO 4.
NO >> Replace the harness.

4. CONFIRM DTC

Ⓜ CONSULT

1. Reconnect all harness connectors.
2. Turn ignition switch ON.
3. Check DTC.

Is DTC still current?

- YES >> GO TO 5.
NO >> Refer to [GI-41, "Intermittent Incident"](#).

5. REAR SIDE AIR BAG SATELLITE SENSOR LH

Ⓜ CONSULT

1. Replace the rear side air bag satellite sensor LH. Refer to [SR-27, "Removal and Installation"](#).
2. Turn ignition switch ON.
3. Check DTC.

B0092 REAR SIDE AIR BAG SATELLITE SENSOR LH

< DTC/CIRCUIT DIAGNOSIS >

Is DTC still current?

YES >> GO TO 6.

NO >> Clear DTC. Inspection End.

6. AIR BAG DIAGNOSIS SENSOR UNIT

Ⓟ CONSULT

1. Replace the air bag diagnosis sensor unit. Refer to [SR-30. "Removal and Installation"](#).

2. Turn ignition switch ON.

3. Check DTC.

Is DTC still current?

YES >> GO TO 7.

NO >> Clear DTC. Inspection End.

7. RELATED HARNESS

Replace the related harness.

>> Inspection End.

B0097 REAR SIDE AIR BAG SATELLITE SENSOR RH

< DTC/CIRCUIT DIAGNOSIS >

B0097 REAR SIDE AIR BAG SATELLITE SENSOR RH

DTC Description

INFOID:000000012159690

DTC DETECTION LOGIC

A

B

C

D

E

F

G

SRC

I

J

K

L

M

N

O

P

B0097 REAR SIDE AIR BAG SATELLITE SENSOR RH

< DTC/CIRCUIT DIAGNOSIS >

DTC	CONSULT name		DTC detecting condition	
B0097	C-PILLAR SAT SEN RH [RESET]	93	Diagnosis condition	When ignition switch is ON.
			Signal (terminal)	Rear side air bag satellite sensor RH (terminal 11 and 12)
			Threshold	—
			Diagnosis delay time	—
	C-PILLAR SAT SEN RH [COMM ERR]	81	Diagnosis condition	When ignition switch is ON.
			Signal (terminal)	Rear side air bag satellite sensor RH (terminal 11 and 12)
			Threshold	—
			Diagnosis delay time	—
	C-PILLAR SAT SEN RH [OPEN]	88	Diagnosis condition	When ignition switch is ON.
			Signal (terminal)	Rear side air bag satellite sensor RH (terminal 11 and 12)
			Threshold	—
			Diagnosis delay time	—
	C-PILLAR SAT SEN RH [UNMATCH]	86	Diagnosis condition	When ignition switch is ON.
			Signal (terminal)	Rear side air bag satellite sensor RH (terminal 11 and 12)
			Threshold	—
			Diagnosis delay time	—
	C-PILLAR SAT SEN RH [OFFSET ERR]	28	Diagnosis condition	When ignition switch is ON.
			Signal (terminal)	Rear side air bag satellite sensor RH (terminal 11 and 12)
			Threshold	—
			Diagnosis delay time	—
	C-PILLAR SAT SEN RH [SELF-DIAG ERR]	25	Diagnosis condition	When ignition switch is ON.
			Signal (terminal)	Rear side air bag satellite sensor RH (terminal 11 and 12)
			Threshold	—
			Diagnosis delay time	—
	C-PILLAR SAT SEN RH [LOWER LIMIT ERR]	23	Diagnosis condition	When ignition switch is ON.
			Signal (terminal)	Rear side air bag satellite sensor RH (terminal 11 and 12)
			Threshold	—
			Diagnosis delay time	—
C-PILLAR SAT SEN RH [UPPER LIMIT ERR]	24	Diagnosis condition	When ignition switch is ON.	
		Signal (terminal)	Rear side air bag satellite sensor RH (terminal 11 and 12)	
		Threshold	—	
		Diagnosis delay time	—	
C-PILLAR SAT SEN RH [GND-SHORT]	11	Diagnosis condition	When ignition switch is ON.	
		Signal (terminal)	Rear side air bag satellite sensor RH (terminal 11 and 12)	
		Threshold	—	
		Diagnosis delay time	—	

POSSIBLE CAUSE

B0097 REAR SIDE AIR BAG SATELLITE SENSOR RH

< DTC/CIRCUIT DIAGNOSIS >

[RESET], [COMM ERR]

- Connection malfunction of harness or connector
- Internal malfunction of rear side air bag satellite sensor RH
- Internal malfunction of air bag diagnosis sensor unit

[OPEN]

- Connection malfunction or open circuit of harness or connector
- Internal malfunction of rear side air bag satellite sensor RH
- Internal malfunction of air bag diagnosis sensor unit

[UNMATCH]

- Air bag diagnosis sensor unit and rear side air bag satellite sensor RH is different from the part specified

[OFFSET ERR], [SELF-DIAG ERR], [LOWER LIMIT ERR], [UPPER LIMIT ERR]

- Internal malfunction of rear side air bag sensor RH
- Internal malfunction of air bag diagnosis sensor unit

[GND-SHORT]

- Connection malfunction or short circuit to ground of harness and connector
- Internal malfunction of rear side air bag satellite sensor RH
- Internal malfunction of air bag diagnosis sensor unit

FAIL-SAFE

—

DTC CONFIRMATION PROCEDURE (With CONSULT)

1.CHECK SELF DIAGNOSTIC RESULT

CONSULT

1. Turn ignition switch ON.
2. Check for DTC using CONSULT.

Is the DTC detected?

YES (Current DTC)>> Refer to [SRC-83, "Diagnosis Procedure"](#).

YES (Past DTC)>> GO TO 2.

NO >> Inspection End.

2.ERASE SELF DIAGNOSTIC RESULT

CONSULT

Erase DTC.

Can the DTC be erased?

YES >> Inspection End.

NO >> Refer to [SRC-83, "Diagnosis Procedure"](#).

DTC CONFIRMATION PROCEDURE (Without CONSULT)

1.CHECK SELF DIAGNOSTIC RESULT

1. Turn ignition switch ON.
2. Check the air bag warning lamp status. Refer to [SRC-15, "SRS Operation Check"](#).

NOTE:

SRS will not enter diagnosis mode if no malfunction is detected in user mode.

Is the DTC detected?

YES >> Refer to [SRC-83, "Diagnosis Procedure"](#).

NO >> Inspection End.

Diagnosis Procedure

INFOID:0000000012159691

1.HARNESS CONNECTOR

B0097 REAR SIDE AIR BAG SATELLITE SENSOR RH

< DTC/CIRCUIT DIAGNOSIS >

Visually inspect all applicable harness connectors for the following:

- Visible damage to connector or terminal
- Loose terminal
- Poor connection

NOTE:

All harness connectors should be inspected from the air bag diagnosis sensor unit to the end component (including any in-line connectors).

Is the inspection result normal?

YES >> GO TO 2.

- NO >> Perform one of the following repairs:
- Visible damage: Replace the harness.
 - Loose terminal: Secure the terminal.
 - Poor connection: Secure the connection.

2.CONFIRM DTC

Ⓢ CONSULT

1. Reconnect all harness connectors.
2. Turn ignition switch ON.
3. Check DTC.

Is DTC still current?

YES >> GO TO 3.

NO >> Refer to [GI-41, "Intermittent Incident"](#).

3.WIRING HARNESS

Check the wiring harness for visible damage.

NOTE:

The entire wiring harness should be inspected from the air bag diagnosis sensor unit to the end component (including any in-line connectors).

Is the inspection result normal?

YES >> GO TO 4.

NO >> Replace the harness.

4.CONFIRM DTC

Ⓢ CONSULT

1. Reconnect all harness connectors.
2. Turn ignition switch ON.
3. Check DTC.

Is DTC still current?

YES >> GO TO 5.

NO >> Refer to [GI-41, "Intermittent Incident"](#).

5.REAR SIDE AIR BAG SATELLITE SENSOR RH

1. Replace the rear side air bag satellite sensor RH. Refer to [SR-27, "Removal and Installation"](#).
2. Turn ignition switch ON.
3. Check for DTC using CONSULT.

Is DTC still current?

YES >> GO TO 6.

NO >> Clear DTC. Inspection End.

6.AIR BAG DIAGNOSIS SENSOR UNIT

Ⓢ CONSULT

1. Replace the air bag diagnosis sensor unit. Refer to [SR-30, "Removal and Installation"](#).
2. Turn ignition switch ON.
3. Check DTC.

Is DTC still current?

YES >> GO TO 7.

NO >> Clear DTC. Inspection End.

B0097 REAR SIDE AIR BAG SATELLITE SENSOR RH

< DTC/CIRCUIT DIAGNOSIS >

7.RELATED HARNESS

Replace the related harness.

>> Inspection End.

A

B

C

D

E

F

G

SRC

I

J

K

L

M

N

O

P

B0093 FRONT DOOR SATELLITE SENSOR LH

< DTC/CIRCUIT DIAGNOSIS >

B0093 FRONT DOOR SATELLITE SENSOR LH

DTC Description

INFOID:000000012159692

DTC DETECTION LOGIC

B0093 FRONT DOOR SATELLITE SENSOR LH

< DTC/CIRCUIT DIAGNOSIS >

DTC	CONSULT name	DTC detecting condition		
B0093	DOOR SATEL SENS LH [RESET]	93	Diagnosis condition	When ignition switch is ON.
			Signal (terminal)	Front door satellite sensor LH (terminal 34 and 44)
			Threshold	—
			Diagnosis delay time	—
	DOOR SATEL SENS LH [COMM ERR]	81	Diagnosis condition	When ignition switch is ON.
			Signal (terminal)	Front door satellite sensor LH (terminal 34 and 44)
			Threshold	—
			Diagnosis delay time	—
	DOOR SATEL SENS LH [OPEN]	88	Diagnosis condition	When ignition switch is ON.
			Signal (terminal)	Front door satellite sensor LH (terminal 34 and 44)
			Threshold	—
			Diagnosis delay time	—
	DOOR SATEL SENS LH [UNMATCH]	86	Diagnosis condition	When ignition switch is ON.
			Signal (terminal)	Front door satellite sensor LH (terminal 34 and 44)
			Threshold	—
			Diagnosis delay time	—
	DOOR SATEL SENS LH [OFFSET ERR]	28	Diagnosis condition	When ignition switch is ON.
			Signal (terminal)	Front door satellite sensor LH (terminal 34 and 44)
			Threshold	—
			Diagnosis delay time	—
	DOOR SATEL SENS LH [SELF-DIAG ERR]	25	Diagnosis condition	When ignition switch is ON.
			Signal (terminal)	Front door satellite sensor LH (terminal 34 and 44)
			Threshold	—
			Diagnosis delay time	—
DOOR SATEL SENS LH [LOWER LIMIT ERR]	23	Diagnosis condition	When ignition switch is ON.	
		Signal (terminal)	Front door satellite sensor LH (terminal 34 and 44)	
		Threshold	—	
		Diagnosis delay time	—	
DOOR SATEL SENS LH [UPPER LIMIT ERR]	24	Diagnosis condition	When ignition switch is ON.	
		Signal (terminal)	Front door satellite sensor LH (terminal 34 and 44)	
		Threshold	—	
		Diagnosis delay time	—	
DOOR SATEL SENS LH [GND-SHORT]	11	Diagnosis condition	When ignition switch is ON.	
		Signal (terminal)	Front door satellite sensor LH (terminal 34 and 44)	
		Threshold	—	
		Diagnosis delay time	—	

A
B
C
D
E
F
G
I
J
K
L
M
N
O
P

SRC

POSSIBLE CAUSE

B0093 FRONT DOOR SATELLITE SENSOR LH

< DTC/CIRCUIT DIAGNOSIS >

[RESET], [COMM ERR]

- Connection malfunction of harness or connector
- Internal malfunction of front door satellite sensor LH
- Internal malfunction of air bag diagnosis sensor unit

[OPEN]

- Connection malfunction or open circuit of harness or connector
- Internal malfunction of front door satellite sensor LH
- Internal malfunction of air bag diagnosis sensor unit

[UNMATCH]

- Air bag diagnosis sensor unit and front door satellite sensor LH is different from the part specified

[OFFSET ERR], [SELF-DIAG ERR], [LOWER LIMIT ERR], [UPPER LIMIT ERR]

- Internal malfunction of front door satellite sensor LH
- Internal malfunction of air bag diagnosis sensor unit

FAIL-SAFE

—

DTC CONFIRMATION PROCEDURE (With CONSULT)

1. CHECK SELF DIAGNOSTIC RESULT

Ⓜ CONSULT

1. Turn ignition switch ON.
2. Check DTC.

Is the DTC detected?

YES (Current DTC)>> Refer to [SRC-88. "Diagnosis Procedure"](#).

YES (Past DTC)>> GO TO 2.

NO >> Inspection End.

2. ERASE SELF DIAGNOSTIC RESULT

Ⓜ CONSULT

Erase DTC.

Can the DTC be erased?

YES >> Inspection End.

NO >> Refer to [SRC-88. "Diagnosis Procedure"](#).

DTC CONFIRMATION PROCEDURE (Without CONSULT)

1. CHECK SELF DIAGNOSTIC RESULT

1. Turn ignition switch ON.
2. Check the air bag warning lamp status. Refer to [SRC-15. "SRS Operation Check"](#).

NOTE:

SRS will not enter diagnosis mode if no malfunction is detected in user mode.

Is the DTC detected?

YES >> Refer to [SRC-88. "Diagnosis Procedure"](#).

NO >> Inspection End.

Diagnosis Procedure

INFOID:000000012159693

1. HARNESS CONNECTOR

Visually inspect all applicable harness connectors for the following:

- Visible damage to connector or terminal
- Loose terminal
- Poor connection

NOTE:

All harness connectors should be inspected from the air bag diagnosis sensor unit to the end component (including any in-line connectors).

B0093 FRONT DOOR SATELLITE SENSOR LH

< DTC/CIRCUIT DIAGNOSIS >

Is the inspection result normal?

- YES >> GO TO 2. A
NO >> Perform one of the following repairs: B
- Visible damage: Replace the harness.
 - Loose terminal: Secure the terminal.
 - Poor connection: Secure the connection.

2.CONFIRM DTC

CONSULT C

1. Reconnect all harness connectors.
2. Turn ignition switch ON.
3. Check DTC. D

Is DTC still current?

- YES >> GO TO 3. E
NO >> Refer to [GI-41, "Intermittent Incident"](#).

3.WIRING HARNESS

Check the wiring harness for visible damage. F

NOTE:

The entire wiring harness should be inspected from the air bag diagnosis sensor unit to the end component (including any in-line connectors). G

Is the inspection result normal?

- YES >> GO TO 4. G
NO >> Replace the harness. SRC

4.CONFIRM DTC

CONSULT I

1. Reconnect all harness connectors.
2. Turn ignition switch ON.
3. Check DTC. J

Is DTC still current?

- YES >> GO TO 5. J
NO >> Refer to [GI-41, "Intermittent Incident"](#).

5.FRONT DOOR SATELLITE SENSOR LH

CONSULT K

1. Replace the front door satellite sensor LH. Refer to [SR-27, "Removal and Installation"](#).
2. Turn ignition switch ON. L
3. Check DTC.

Is DTC still current?

- YES >> GO TO 6. M
NO >> Clear DTC. Inspection End.

6.AIR BAG DIAGNOSIS SENSOR UNIT

CONSULT N

1. Replace the air bag diagnosis sensor unit. Refer to [SR-30, "Removal and Installation"](#).
2. Turn ignition switch ON. O
3. Check DTC.

Is DTC still current?

- YES >> GO TO 7. P
NO >> Clear DTC. Inspection End.

7.RELATED HARNESS

Replace the related harness.

>> Inspection End.

B0098 FRONT DOOR SATELLITE SENSOR RH

< DTC/CIRCUIT DIAGNOSIS >

B0098 FRONT DOOR SATELLITE SENSOR RH

DTC Description

INFOID:000000012159694

DTC DETECTION LOGIC

B0098 FRONT DOOR SATELLITE SENSOR RH

< DTC/CIRCUIT DIAGNOSIS >

DTC	CONSULT name	DTC detecting condition			
B0098	DOOR SATEL SENS RH [RESET]	93	Diagnosis condition	When ignition switch is ON.	A
			Signal (terminal)	Front door satellite sensor RH (Terminal 32 and 42)	B
			Threshold	—	
			Diagnosis delay time	—	
	DOOR SATEL SENS RH [COMM ERR]	81	Diagnosis condition	When ignition switch is ON.	C
			Signal (terminal)	Front door satellite sensor RH (Terminal 32 and 42)	D
			Threshold	—	
			Diagnosis delay time	—	
	DOOR SATEL SENS RH [OPEN]	88	Diagnosis condition	When ignition switch is ON.	E
			Signal (terminal)	Front door satellite sensor RH (Terminal 32 and 42)	F
			Threshold	—	
			Diagnosis delay time	—	
	DOOR SATEL SENS RH [UNMATCH]	86	Diagnosis condition	When ignition switch is ON.	G
			Signal (terminal)	Front door satellite sensor RH (Terminal 32 and 42)	SRC
			Threshold	—	
			Diagnosis delay time	—	
	DOOR SATEL SENS RH [OFFSET ERR]	28	Diagnosis condition	When ignition switch is ON.	I
			Signal (terminal)	Front door satellite sensor RH (Terminal 32 and 42)	J
			Threshold	—	
			Diagnosis delay time	—	
	DOOR SATEL SENS RH [SELF-DIAG ERR]	25	Diagnosis condition	When ignition switch is ON.	K
			Signal (terminal)	Front door satellite sensor RH (Terminal 32 and 42)	L
			Threshold	—	
			Diagnosis delay time	—	
	DOOR SATEL SENS RH [LOWER LIMIT ERR]	23	Diagnosis condition	When ignition switch is ON.	M
			Signal (terminal)	Front door satellite sensor RH (Terminal 32 and 42)	N
			Threshold	—	
			Diagnosis delay time	—	
DOOR SATEL SENS RH [UPPER LIMIT ERR]	24	Diagnosis condition	When ignition switch is ON.	O	
		Signal (terminal)	Front door satellite sensor RH (Terminal 32 and 42)	P	
		Threshold	—		
		Diagnosis delay time	—		
DOOR SATEL SENS RH [GND-SHORT]	11	Diagnosis condition	When ignition switch is ON.		
		Signal (terminal)	Front door satellite sensor RH (Terminal 32 and 42)		
		Threshold	—		
		Diagnosis delay time	—		

POSSIBLE CAUSE

B0098 FRONT DOOR SATELLITE SENSOR RH

< DTC/CIRCUIT DIAGNOSIS >

[RESET], [COMM ERR]

- Connection malfunction of harness or connector
- Internal malfunction of front door satellite sensor RH
- Internal malfunction of air bag diagnosis sensor unit

[OPEN]

- Connection malfunction or open circuit of harness or connector
- Internal malfunction of front door satellite sensor RH
- Internal malfunction of air bag diagnosis sensor unit

[UNMATCH]

- Air bag diagnosis sensor unit and front door satellite sensor RH is different from the part specified

[OFFSET ERR], [SELF-DIAD ERR], [LOWER LIMIT ERR], [UPPER LIMIT ERR]

- Internal malfunction of front door satellite sensor RH
- Internal malfunction of air bag diagnosis sensor unit

[GND-SHORT]

- Connection malfunction or short circuit to ground of harness and connector
- Internal malfunction of front door satellite sensor RH
- Internal malfunction of air bag diagnosis sensor unit

FAIL-SAFE

—

DTC CONFIRMATION PROCEDURE (With CONSULT)

1. CHECK SELF DIAGNOSTIC RESULT

1. Turn ignition switch ON.
2. Check for DTC using CONSULT.

Is the DTC detected?

- YES (Current DTC)>> Refer to [SRC-92. "Diagnosis Procedure"](#).
- YES (Past DTC)>> GO TO 2.
- NO >> Inspection End.

2. ERASE SELF DIAGNOSTIC RESULT

Erase the DTC using CONSULT.

Can the DTC be erased?

- YES >> Inspection End.
- NO >> Refer to [SRC-92. "Diagnosis Procedure"](#).

DTC CONFIRMATION PROCEDURE (Without CONSULT)

1. CHECK SELF DIAGNOSTIC RESULT

1. Turn ignition switch ON.
2. Check the air bag warning lamp status. Refer to [SRC-15. "SRS Operation Check"](#).

NOTE:

SRS will not enter diagnosis mode if no malfunction is detected in user mode.

Is the DTC detected?

- YES >> Refer to [SRC-92. "Diagnosis Procedure"](#).
- NO >> Inspection End.

Diagnosis Procedure

INFOID:000000012159695

1. HARNESS CONNECTOR

Visually inspect all applicable harness connectors for the following:

- Visible damage to connector or terminal
- Loose terminal

B0098 FRONT DOOR SATELLITE SENSOR RH

< DTC/CIRCUIT DIAGNOSIS >

- Poor connection

NOTE:

All harness connectors should be inspected from the air bag diagnosis sensor unit to the end component (including any in-line connectors).

Is the inspection result normal?

YES >> GO TO 2.

- NO >> Perform one of the following repairs:
- Visible damage: Replace the harness.
 - Loose terminal: Secure the terminal.
 - Poor connection: Secure the connection.

2. CONFIRM DTC

Ⓜ CONSULT

1. Reconnect all harness connectors.
2. Turn ignition switch ON.
3. Check DTC.

Is DTC still current?

YES >> GO TO 3.

NO >> Refer to [GI-41, "Intermittent Incident"](#).

3. WIRING HARNESS

Check the wiring harness for visible damage.

NOTE:

The entire wiring harness should be inspected from the air bag diagnosis sensor unit to the end component (including any in-line connectors).

Is the inspection result normal?

YES >> GO TO 4.

NO >> Replace the harness.

4. CONFIRM DTC

Ⓜ CONSULT

1. Reconnect all harness connectors.
2. Turn ignition switch ON.
3. Check DTC.

Is DTC still current?

YES >> GO TO 5.

NO >> Refer to [GI-41, "Intermittent Incident"](#).

5. FRONT DOOR SATELLITE SENSOR RH

Ⓜ CONSULT

1. Replace the front door satellite sensor RH. Refer to [SR-27, "Removal and Installation"](#).
2. Turn ignition switch ON.
3. Check DTC.

Is DTC still current?

YES >> GO TO 6.

NO >> Clear DTC. Inspection End.

6. AIR BAG DIAGNOSIS SENSOR UNIT

Ⓜ CONSULT

1. Replace the air bag diagnosis sensor unit. Refer to [SR-30, "Removal and Installation"](#).
2. Turn ignition switch ON.
3. Check DTC.

Is DTC still current?

YES >> GO TO 7.

NO >> Clear DTC. Inspection End.

7. RELATED HARNESS

Replace the related harness.

B0098 FRONT DOOR SATELLITE SENSOR RH

< DTC/CIRCUIT DIAGNOSIS >

>> Inspection End.

B00A0 OCCUPANT CLASSIFICATION SYSTEM CONTROL UNIT

< DTC/CIRCUIT DIAGNOSIS >

B00A0 OCCUPANT CLASSIFICATION SYSTEM CONTROL UNIT

Description

INFOID:000000012159696

DTC B00A0 OCCUPANT CLASSIFICATION SYSTEM (OCS)

The OCS control unit is wired to the air bag diagnosis sensor unit. The air bag diagnosis sensor unit will monitor the OCS for failures and interruptions in communication between the OCS control unit and the air bag diagnosis sensor unit.

PART LOCATION

Refer to [SRC-5, "Component Parts Location"](#).

DTC Description

INFOID:000000012159697

DTC DETECTION LOGIC

DTC	CONSULT screen items (Trouble diagnosis content)	DTC detecting condition
B00A0-00	OCCUPANT SENS [Occupant Classification System (Subfault)]	[ABNORMAL VOLTAGE] Power supply malfunction of occupant detection sensor
B00A0-02		[UNIT MALFUNC] Malfunction of occupant detection sensor
B00A0-09		[UNIT MALFUNC] Malfunction of occupant detection sensor
B00A0-04	OCCUPANT SENS C/U [Occupant Classification System (Subfault)]	[UNIT MALFUNC] Malfunction of occupant detection sensor control unit
B00A0-83		[COMM ERR] <ul style="list-style-type: none"> Communication malfunction of occupant detection sensor control unit Communication blank of occupant detection sensor control unit
B00A0-86		[COMM ERR] <ul style="list-style-type: none"> Communication malfunction of occupant detection sensor control unit Communication blank of occupant detection sensor control unit
B00A0-87		[COMM ERR] <ul style="list-style-type: none"> Communication malfunction of occupant detection sensor control unit Communication blank of occupant detection sensor control unit
B00A0-88		[COMM ERR] <ul style="list-style-type: none"> Communication malfunction of occupant detection sensor control unit Communication blank of occupant detection sensor control unit
B00A0-8F		[UNDEFINED] Undefined status of occupant detection sensor control unit
B00A0-93		[RESET] Reset malfunction of occupant detection sensor control unit

DTC CONFIRMATION PROCEDURE (With CONSULT)

1. CHECK SELF DIAGNOSTIC RESULT

CONSULT

- Turn ignition switch ON.
- Check DTC.

Is the DTC detected?

YES (Current DTC)>>Refer to:

- B00A0-00, -02 or -09: [SRC-96, "Diagnosis Procedure \(B00A0-00, -02 or -09\)"](#)
- B00A0-04: [SRC-97, "Diagnosis Procedure \(B00A0-04\)"](#)
- B00A0-83, -86, -87, -88 or -8F: [SRC-98, "Diagnosis Procedure \(B00A0-83, -86, -87, -88 or -8F\)"](#)
- B00A0-93: [SRC-99, "Diagnosis Procedure \(B00A0-93\)"](#)

YES (Past DTC)>>GO TO 2.

NO >> Inspection End.

2. ERASE SELF DIAGNOSTIC RESULT

B00A0 OCCUPANT CLASSIFICATION SYSTEM CONTROL UNIT

< DTC/CIRCUIT DIAGNOSIS >

CONSULT

Erase DTC.

Can the DTC be erased?

YES >> Inspection End.

NO >> Refer to:

- B00A0-00, -02 or -09: [SRC-96, "Diagnosis Procedure \(B00A0-00, -02 or -09\)"](#)
- B00A0-04: [SRC-97, "Diagnosis Procedure \(B00A0-04\)"](#)
- B00A0-83, -86, -87, -88 or -8F: [SRC-98, "Diagnosis Procedure \(B00A0-83, -86, -87, -88 or -8F\)"](#)
- B00A0-93: [SRC-99, "Diagnosis Procedure \(B00A0-93\)"](#)

DTC CONFIRMATION PROCEDURE (Without CONSULT)

1.CHECK SELF-DIAG RESULT

1. Turn ignition switch ON.

2. Check the air bag warning lamp status. Refer to [SRC-15, "SRS Operation Check"](#).

NOTE:

SRS does not enter the diagnosis mode if no malfunction is detected in the user mode.

Is the DTC detected?

YES >> Refer to:

- B00A0-00, -02 or -09: [SRC-96, "Diagnosis Procedure \(B00A0-00, -02 or -09\)"](#)
- B00A0-04: [SRC-97, "Diagnosis Procedure \(B00A0-04\)"](#)
- B00A0-83, -86, -87, -88 or -8F: [SRC-98, "Diagnosis Procedure \(B00A0-83, -86, -87, -88 or -8F\)"](#)
- B00A0-93: [SRC-99, "Diagnosis Procedure \(B00A0-93\)"](#)

NO >> Inspection End.

Diagnosis Procedure (B00A0-00, -02 or -09)

INFOID:000000012159698

1.HARNES CONNECTOR

Visually inspect all applicable harness connectors for the following:

- Visible damage to connector or terminal
- Loose terminal
- Poor connection

NOTE:

All harness connectors should be inspected from the air bag diagnosis unit to the end component (including any in-line connectors)

Is the inspection result normal?

YES >> GO TO 3.

NO >> Perform the following repairs. Then, GO TO 2.

- Visible damage: Replace the harness.
- Loose terminal: Secure the terminal.
- Poor connection: Secure the connection.

2.CONFIRM DTC

CONSULT

1. Reconnect all harness connectors.

2. Turn ignition switch ON.

3. Check DTC.

Is DTC still current?

YES >> GO TO 3.

NO >> Clear DTC and perform zero point reset. Refer to [SRC-39, "ZERO POINT RESET : Description"](#).

3.REPLACE OCS CONTROL UNIT AND SENSORS

CONSULT

1. Replace the OCS control unit and sensors. Refer to [SR-34, "Removal and Installation - Control Unit"](#).

2. Turn ignition switch ON.

3. Check DTC.

Is DTC still current?

YES >> GO TO 4.

B00A0 OCCUPANT CLASSIFICATION SYSTEM CONTROL UNIT

< DTC/CIRCUIT DIAGNOSIS >

NO >> Clear DTC and perform zero point reset. Refer to [SRC-39, "ZERO POINT RESET : Description"](#).

4. AIR BAG DIAGNOSIS SENSOR UNIT

CONSULT

1. Replace the air bag diagnosis sensor unit. Refer to [SR-30, "Removal and Installation"](#).
2. Turn ignition switch ON.
3. Check DTC.

Is DTC still current?

YES >> GO TO 5.

NO >> Clear DTC and perform zero point reset. Refer to [SRC-39, "ZERO POINT RESET : Description"](#).

5. RELATED HARNESS

CONSULT

1. Replace the related harnesses (OCS sensors to OCS control unit, OCS control unit to seat, seat to main harness, main harness to air bag diagnosis sensor unit).
2. Turn ignition switch ON.
3. Check DTC.

Is DTC still current?

YES >> GO TO 6.

NO >> Clear DTC and perform zero point reset. Refer to [SRC-39, "ZERO POINT RESET : Description"](#).

6. REPLACE PASSENGER SEAT CUSHION FRAME

CONSULT

1. Replace the passenger seat cushion frame. Refer to [SE-107, "PASSENGER SIDE : Seatback"](#).
2. Clear DTC and perform zero point reset. Refer to [SRC-39, "ZERO POINT RESET : Description"](#).

>> Inspection End.

Diagnosis Procedure (B00A0-04)

INFOID:000000012159699

1. HARNESS CONNECTOR

Visually inspect all applicable harness connectors for the following:

- Visible damage to connector or terminal
- Loose terminal
- Poor connection

NOTE:

All harness connectors should be inspected from the air bag diagnosis unit to the end component (including any in-line connectors)

Is the inspection result normal?

YES >> GO TO 3.

NO >> Perform the following repairs. Then, GO TO 2.

- Visible damage: Replace the harness.
- Loose terminal: Secure the terminal.
- Poor connection: Secure the connection.

2. CONFIRM DTC

CONSULT

1. Reconnect all harness connectors.
2. Turn ignition switch ON.
3. Check DTC.

Is DTC still current?

YES >> GO TO 3.

NO >> Clear DTC and perform zero point reset. Refer to [SRC-39, "ZERO POINT RESET : Description"](#).

3. REPLACE OCS CONTROL UNIT

CONSULT

1. Replace the OCS control unit. Refer to [SR-34, "Removal and Installation - Control Unit"](#).
2. Turn ignition switch ON.

B00A0 OCCUPANT CLASSIFICATION SYSTEM CONTROL UNIT

< DTC/CIRCUIT DIAGNOSIS >

3. Check DTC.

Is DTC still current?

YES >> GO TO 4.

NO >> Clear DTC and perform zero point reset. Refer to [SRC-39, "ZERO POINT RESET : Description"](#).

4. AIR BAG DIAGNOSIS SENSOR UNIT

Ⓟ CONSULT

1. Replace the air bag diagnosis sensor unit. Refer to [SR-30, "Removal and Installation"](#).

2. Turn ignition switch ON.

3. Check DTC.

Is DTC still current?

YES >> GO TO 5.

NO >> Clear DTC and perform zero point reset. Refer to [SRC-39, "ZERO POINT RESET : Description"](#).

5. RELATED HARNESS

Ⓟ CONSULT

1. Replace the related harnesses (OCS sensors to OCS control unit, OCS control unit to seat, seat to main harness, main harness to air bag diagnosis sensor unit)

2. Turn ignition switch ON.

3. Check DTC.

Is DTC still current?

YES >> GO TO 6.

NO >> Clear DTC and perform zero point reset. Refer to [SRC-39, "ZERO POINT RESET : Description"](#).

6. REPLACE OCS SENSORS

Ⓟ CONSULT

1. Replace the OCS sensors. Refer to [SR-34, "Removal and Installation - Control Unit"](#).

2. Turn ignition switch ON.

3. Check for DTC.

Is DTC still current?

YES >> GO TO 7.

NO >> Clear DTC and perform zero point reset. Refer to [SRC-39, "ZERO POINT RESET : Description"](#).

7. REPLACE PASSENGER SEAT CUSHION FRAME

1. Replace the passenger seat cushion frame. Refer to [SE-108, "PASSENGER SIDE : Seat Cushion"](#).

2. Clear DTC and perform zero point reset. Refer to [SRC-39, "ZERO POINT RESET : Description"](#).

>> Inspection End.

Diagnosis Procedure (B00A0-83, -86, -87, -88 or -8F)

INFOID:000000012159700

1. HARNESS CONNECTOR

Visually inspect all applicable harness connectors for the following:

- Visible damage to connector or terminal
- Loose terminal
- Poor connection

NOTE:

All harness connectors should be inspected from the air bag diagnosis unit to the end component (including any in-line connectors)

Is the inspection result normal?

YES >> GO TO 3.

NO >> Perform the following repairs. Then, GO TO 2.

- Visible damage: Replace the harness.
- Loose terminal: Secure the terminal.
- Poor connection: Secure the connection.

2. CONFIRM DTC

B00A0 OCCUPANT CLASSIFICATION SYSTEM CONTROL UNIT

< DTC/CIRCUIT DIAGNOSIS >

CONSULT

1. Reconnect all harness connectors.
2. Turn ignition switch ON.
3. Check for DTC using CONSULT.

Is DTC still current?

YES >> GO TO 3.

NO >> Clear DTC and perform zero point reset. Refer to [SRC-39, "ZERO POINT RESET : Description"](#).

3.REPLACE OCS CONTROL UNIT AND SENSORS

CONSULT

1. Replace the OCS control unit and sensors. Refer to [SR-34, "Removal and Installation - Control Unit"](#).
2. Turn ignition switch ON.
3. Check DTC.

Is DTC still current?

YES >> GO TO 4.

NO >> Clear DTC and perform zero point reset. Refer to [SRC-39, "ZERO POINT RESET : Description"](#).

4.AIR BAG DIAGNOSIS SENSOR UNIT

CONSULT

1. Replace the air bag diagnosis sensor unit. Refer to [SR-30, "Removal and Installation"](#).
2. Turn ignition switch ON.
3. Check DTC.

Is DTC still current?

YES >> GO TO 5.

NO >> Clear DTC and perform zero point reset. Refer to [SRC-39, "ZERO POINT RESET : Description"](#).

5.RELATED HARNESS

CONSULT

1. Replace the related harnesses (OCS sensors to OCS control unit, OCS control unit to seat, seat to main harness, main harness to air bag diagnosis sensor unit).
2. Turn ignition switch ON.
3. Check DTC.

Is DTC still current?

YES >> GO TO 6.

NO >> Clear DTC and perform zero point reset. Refer to [SRC-39, "ZERO POINT RESET : Description"](#).

6.REPLACE PASSENGER SEAT CUSHION FRAME

CONSULT

1. Replace the passenger seat cushion frame. Refer to [SE-108, "PASSENGER SIDE : Seat Cushion"](#).
2. Clear DTC and perform zero point reset. Refer to [SRC-39, "ZERO POINT RESET : Description"](#).

>> Inspection End.

Diagnosis Procedure (B00A0-93)

INFOID:0000000012159701

1.PERFORM ZERO POINT RESET

CONSULT

1. Perform zero point reset. Refer to [SRC-39, "ZERO POINT RESET : Description"](#).
2. Turn ignition switch ON.
3. Check DTC.

Is DTC still current?

YES >> GO TO 2.

NO >> Clear DTC. Inspection End.

2.HARNESS CONNECTOR

Visually inspect all applicable harness connectors for the following:

- Visible damage to connector or terminal

B00A0 OCCUPANT CLASSIFICATION SYSTEM CONTROL UNIT

< DTC/CIRCUIT DIAGNOSIS >

- Loose terminal
- Poor connection

NOTE:

All harness connectors should be inspected from the air bag diagnosis unit to the end component (including any in-line connectors)

Is the inspection result normal?

- YES >> GO TO 4.
NO >> Perform the following repairs. Then, GO TO 3.
- Visible damage: Replace the harness.
 - Loose terminal: Secure the terminal.
 - Poor connection: Secure the connection.

3.CONFIRM DTC

Ⓜ CONSULT

1. Reconnect all harness connectors.
2. Turn ignition switch ON.
3. Check DTC.

Is DTC still current?

- YES >> GO TO 4.
NO >> Clear DTC and perform zero point reset. Refer to [SRC-39, "ZERO POINT RESET : Description"](#).

4.REPLACE OCS CONTROL UNIT

Ⓜ CONSULT

1. Replace the OCS control unit. Refer to [SR-34, "Removal and Installation - Control Unit"](#).
2. Turn ignition switch ON.
3. Check DTC.

Is DTC still current?

- YES >> GO TO 5.
NO >> Clear DTC and perform zero point reset. Refer to [SRC-39, "ZERO POINT RESET : Description"](#).

5.AIR BAG DIAGNOSIS SENSOR UNIT

Ⓜ CONSULT

1. Replace the air bag diagnosis sensor unit. Refer to [SR-30, "Removal and Installation"](#).
2. Turn ignition switch ON.
3. Check DTC.

Is DTC still current?

- YES >> GO TO 6.
NO >> Clear DTC and perform zero point reset. Refer to [SRC-39, "ZERO POINT RESET : Description"](#).

6.RELATED HARNESS

Ⓜ CONSULT

1. Replace the related harnesses (OCS sensors to OCS control unit, OCS control unit to seat, seat to main harness, main harness to air bag diagnosis sensor unit)
2. Turn ignition switch ON.
3. Check DTC.

Is DTC still current?

- YES >> GO TO 7.
NO >> Clear DTC and perform zero point reset. Refer to [SRC-39, "ZERO POINT RESET : Description"](#).

7.REPLACE OCS SENSORS

Ⓜ CONSULT

1. Replace the OCS sensors. Refer to [SR-34, "Removal and Installation - Control Unit"](#).
2. Turn ignition switch ON.
3. Check DTC.

Is DTC still current?

- YES >> GO TO 8.
NO >> Clear DTC and perform zero point reset. Refer to [SRC-39, "ZERO POINT RESET : Description"](#).

B00A0 OCCUPANT CLASSIFICATION SYSTEM CONTROL UNIT

< DTC/CIRCUIT DIAGNOSIS >

8. REPLACE PASSENGER SEAT CUSHION FRAME

CONSULT

1. Replace the passenger seat cushion frame. Refer to [SE-108, "PASSENGER SIDE : Seat Cushion"](#).
2. Clear DTC and perform zero point reset. Refer to [SRC-39, "ZERO POINT RESET : Description"](#).

>> Inspection End.

A
B
C
D
E
F
G
I
J
K
L
M
N
O
P

SRC

B00D5 PASSENGER AIR BAG OFF INDICATOR

< DTC/CIRCUIT DIAGNOSIS >

B00D5 PASSENGER AIR BAG OFF INDICATOR

DTC Description

INFOID:000000012159702

DTC DETECTION LOGIC

DTC	CONSULT name	DTC detecting condition		
B00D5	PASS A/B INDCTR CKT [UNIT MALFUNC]	04	Diagnosis condition	When ignition is ON.
			Signal (terminal)	Front passenger air bag OFF indicator (Terminal 27 and 47)
			Threshold	—
			Diagnosis delay time	—
	PASS A/B INDCTR CKT [PWR-SHORT/OPEN]	15	Diagnosis condition	When ignition is ON.
			Signal (terminal)	Front passenger air bag OFF indicator (Terminal 27 and 47)
			Threshold	—
			Diagnosis delay time	—
	PASS A/B INDCTR CKT [OPEN]	13	Diagnosis condition	When ignition is ON.
			Signal (terminal)	Front passenger air bag OFF indicator (Terminal 27 and 47)
			Threshold	—
			Diagnosis delay time	—
	PASS A/B INDCTR CKT [VB-SHORT]	12	Diagnosis condition	When ignition is ON.
			Signal (terminal)	Front passenger air bag OFF indicator (Terminal 27 and 47)
			Threshold	—
			Diagnosis delay time	—
	PASS A/B INDCTR CKT [GND-SHORT]	11	Diagnosis condition	When ignition is ON.
			Signal (terminal)	Front passenger air bag OFF indicator (Terminal 27 and 47)
			Threshold	—
			Diagnosis delay time	—

POSSIBLE CAUSE

[UNIT MALFUNC]

- Internal malfunction of front passenger air bag OFF indicator
- Internal malfunction of air bag diagnosis sensor unit

[PWE-SHORT/OPEN]

- Connection malfunction or short circuit to power supply of harness and connector
- Connection malfunction or open circuit of harness and connector
- Internal malfunction of front passenger air bag OFF indicator
- Internal malfunction of air bag diagnosis sensor unit

[OPEN]

- Connection malfunction or open circuit of harness and connector
- Internal malfunction of front passenger air bag OFF indicator
- Internal malfunction of air bag diagnosis sensor unit

[VB-SHORT]

- Connection malfunction or short circuit to power supply of harness and connector

B00D5 PASSENGER AIR BAG OFF INDICATOR

< DTC/CIRCUIT DIAGNOSIS >

- Internal malfunction of front passenger air bag OFF indicator
- Internal malfunction of air bag diagnosis sensor unit

A

[GND-SHORT]

- Connection malfunction or short circuit to ground of harness and connector
- Internal malfunction of front passenger air bag OFF indicator
- Internal malfunction of air bag diagnosis sensor unit

B

DTC CONFIRMATION PROCEDURE (With CONSULT)

C

1. CHECK SELF DIAGNOSTIC RESULT

Ⓜ CONSULT

1. Turn ignition switch ON.
2. Check DTC.

D

Is the DTC detected?

E

YES (Current DTC)>> Refer to [SRC-103, "Diagnosis Procedure"](#).

YES (Past DTC)>> GO TO 2.

NO >> Inspection End.

F

2. ERASE SELF DIAGNOSTIC RESULT

Ⓜ CONSULT

Erase DTC.

G

Can the DTC be erased?

YES >> Inspection End.

NO >> Refer to [SRC-103, "Diagnosis Procedure"](#).

SRC

DTC CONFIRMATION PROCEDURE (Without CONSULT)

1. CHECK SELF DIAGNOSTIC RESULT

I

Ⓜ CONSULT

1. Turn ignition switch ON.
2. Check the air bag warning lamp status. Refer to [SRC-15, "SRS Operation Check"](#).

J

NOTE:

SRS will not enter diagnosis mode if no malfunction is detected in user mode.

Is the DTC detected?

K

YES >> Refer to [SRC-103, "Diagnosis Procedure"](#).

NO >> Inspection End.

Diagnosis Procedure

INFOID:000000012159703

L

1. HARNESS CONNECTOR

Visually inspect all applicable harness connectors for the following:

- Visible damage to connector or terminal
- Loose terminal
- Poor connection

M

N

NOTE:

All harness connectors should be inspected from the air bag diagnosis sensor unit to the end component (including any in-line connectors).

O

Is the inspection result normal?

YES >> GO TO 2.

NO >> Perform one of the following repairs:

- Visible damage: Replace the harness.
- Loose terminal: Secure the terminal.
- Poor connection: Secure the connection.

P

2. CONFIRM DTC

Ⓜ CONSULT

1. Reconnect all harness connectors.

B00D5 PASSENGER AIR BAG OFF INDICATOR

< DTC/CIRCUIT DIAGNOSIS >

2. Turn ignition switch ON.
3. Check DTC.

Is DTC still current?

- YES >> GO TO 3.
NO >> Refer to [GI-41, "Intermittent Incident"](#).

3. WIRING HARNESS

Check the wiring harness for visible damage.

NOTE:

The entire wiring harness should be inspected from the air bag diagnosis sensor unit to the end component (including any in-line connectors).

Is the inspection result normal?

- YES >> GO TO 4.
NO >> Replace the harness.

4. CONFIRM DTC

Ⓟ CONSULT

1. Reconnect all harness connectors.
2. Turn ignition switch ON.
3. Check DTC.

Is DTC still current?

- YES >> GO TO 5.
NO >> Refer to [GI-41, "Intermittent Incident"](#).

5. PASSENGER AIR BAG OFF INDICATOR

Ⓟ CONSULT

1. Replace the passenger air bag off indicator.
2. Turn ignition switch ON.
3. Check DTC.

Is DTC still current?

- YES >> GO TO 6.
NO >> Clear DTC. Inspection End.

6. AIR BAG DIAGNOSIS SENSOR UNIT

Ⓟ CONSULT

1. Replace the air bag diagnosis sensor unit. Refer to [SR-30, "Removal and Installation"](#).
2. Turn ignition switch ON.
3. Check DTC.

Is DTC still current?

- YES >> GO TO 7.
NO >> Clear DTC. Inspection End.

7. RELATED HARNESS

Replace the related harness.

>> Inspection End.

B1428 SEAT BELT BUCKLE SWITCH LH

< DTC/CIRCUIT DIAGNOSIS >

B1428 SEAT BELT BUCKLE SWITCH LH

DTC Description

INFOID:000000012159704

DTC DETECTION LOGIC

DTC	CONSULT name	DTC detecting condition		
B1428	BUCKLE SW LH [OPEN]	13	Diagnosis condition	When ignition switch is ON.
			Signal (terminal)	Seat belt buckle switch LH circuit is open. (terminal 67).
			Threshold	—
			Diagnosis delay time	—
	BUCKLE SW LH [VB-SHORT]	12	Diagnosis condition	When ignition switch is ON.
			Signal (terminal)	Seat belt buckle switch LH circuit is shorted to power. (terminal 67).
			Threshold	—
			Diagnosis delay time	—
	BUCKLE SW LH [GND-SHORT]	11	Diagnosis condition	When ignition switch is ON.
			Signal (terminal)	Seat belt buckle switch LH circuit is shorted to ground (terminal 67).
			Threshold	—
			Diagnosis delay time	—
	BUCKLE SW LH [UNDEFINED]	00	Diagnosis condition	When ignition switch is ON.
			Signal (terminal)	Seat belt buckle switch (terminal 67).
			Threshold	—
			Diagnosis delay time	—

POSSIBLE CAUSE

[OPEN]

- Connection malfunction or open circuit of harness and connector
- Internal malfunction of seat belt buckle switch LH

[VB-SHORT]

- Connection malfunction or short circuit to power supply of harness and connector
- Internal malfunction of seat belt buckle switch LH
- Internal malfunction of diagnosis sensor unit

[GND-SHORT]

- Connection malfunction or short circuit to ground of harness and connector
- Internal malfunction of seat belt buckle switch LH
- Internal malfunction of diagnosis sensor unit

[UNDEFINED]

- Connection malfunction or open circuit of harness and connector
- Internal malfunction of seat belt buckle switch LH
- Internal malfunction of diagnosis sensor unit

FAIL-SAFE

—

DTC CONFIRMATION PROCEDURE (With CONSULT)

1. CHECK SELF DIAGNOSTIC RESULT

B1428 SEAT BELT BUCKLE SWITCH LH

< DTC/CIRCUIT DIAGNOSIS >

Ⓟ CONSULT

1. Turn ignition switch ON.
2. Check DTC.

Is the DTC detected?

YES (Current DTC)>> Refer to [SRC-106, "Diagnosis Procedure"](#).

YES (Past DTC)>> GO TO 2.

NO >> Inspection End.

2.ERASE SELF DIAGNOSTIC RESULT

Ⓟ CONSULT

Erase DTC.

Can the DTC be erased?

YES >> Inspection End.

NO >> Refer to [SRC-106, "Diagnosis Procedure"](#).

DTC CONFIRMATION PROCEDURE (Without CONSULT)

1.CHECK SELF DIAGNOSTIC RESULT

1. Turn ignition switch ON.
2. Check the air bag warning lamp status. Refer to [SRC-15, "SRS Operation Check"](#).

NOTE:

SRS will not enter diagnosis mode if no malfunction is detected in user mode.

Is the DTC detected?

YES >> Refer to [SRC-106, "Diagnosis Procedure"](#).

NO >> Inspection End.

Diagnosis Procedure

INFOID:0000000012159705

1.HARNESS CONNECTOR

Visually inspect all applicable harness connectors for the following:

- Visible damage to connector or terminal
- Loose terminal
- Poor connection

NOTE:

All harness connectors should be inspected from the air bag diagnosis sensor unit to the end component (including any in-line connectors).

Is the inspection result normal?

YES >> GO TO 2.

- NO >> Perform one of the following repairs:
- Visible damage: Replace the harness.
 - Loose terminal: Secure the terminal.
 - Poor connection: Secure the connection.

2.CONFIRM DTC

Ⓟ CONSULT

1. Reconnect all harness connectors.
2. Turn ignition switch ON.
3. Check DTC.

Is DTC still current?

YES >> GO TO 3.

NO >> Refer to [GI-41, "Intermittent Incident"](#).

3.WIRING HARNESS

Check the wiring harness for visible damage.

NOTE:

The entire wiring harness should be inspected from the air bag diagnosis sensor unit to the end component (including any in-line connectors).

Is the inspection result normal?

B1428 SEAT BELT BUCKLE SWITCH LH

< DTC/CIRCUIT DIAGNOSIS >

- YES >> GO TO 4.
NO >> Replace the harness.

4.CONFIRM DTC

Ⓜ CONSULT

1. Reconnect all harness connectors.
2. Turn ignition switch ON.
3. Check DTC.

Is DTC still current?

- YES >> GO TO 5.
NO >> Refer to [GI-41, "Intermittent Incident"](#).

5.SEAT BELT BUCKLE SWITCH LH

Ⓜ CONSULT

1. Replace the seat belt buckle switch LH. Refer to [SB-8, "SEAT BELT RETRACTOR : Removal and Installation"](#).
2. Turn ignition switch ON.
3. Check DTC.

Is DTC still current?

- YES >> GO TO 6.
NO >> Clear DTC. Inspection End.

6.AIR BAG DIAGNOSIS SENSOR UNIT

Ⓜ CONSULT

1. Replace the air bag diagnosis sensor unit. Refer to [SR-30, "Removal and Installation"](#).
2. Turn ignition switch ON.
3. Check DTC.

Is DTC still current?

- YES >> GO TO 7.
NO >> Clear DTC. Inspection End.

7.RELATED HARNESS

Replace the related harness.

>> Inspection End.

A
B
C
D
E
F
G
I
J
K
L
M
N
O
P

SRC

B1429 SEAT BELT BUCKLE SWITCH RH

< DTC/CIRCUIT DIAGNOSIS >

B1429 SEAT BELT BUCKLE SWITCH RH

DTC Description

INFOID:000000012159706

DTC DETECTION LOGIC

DTC	CONSULT name	DTC detecting condition		
B1429	BUCKLE SW RH [OPEN]	13	Diagnosis condition	When ignition switch is ON.
			Signal (terminal)	Seat belt buckle switch RH circuit is open. (terminal 10 and 20)
			Threshold	—
			Diagnosis delay time	—
B1429	BUCKLE SW RH [VB-SHORT]	12	Diagnosis condition	When ignition switch is ON.
			Signal (terminal)	Seat belt buckle switch RH circuit is open. (terminal 10 and 20)
			Threshold	—
			Diagnosis delay time	—
B1429	BUCKLE SW RH [GND-SHORT]	11	Diagnosis condition	When ignition switch is ON.
			Signal (terminal)	Seat belt buckle switch RH circuit is open. (terminal 10 and 20)
			Threshold	—
			Diagnosis delay time	—
B1429	BUCKLE SW RH [UNDEFINED]	00	Diagnosis condition	When ignition switch is ON.
			Signal (terminal)	Seat belt buckle switch RH circuit is open. (terminal 10 and 20)
			Threshold	—
			Diagnosis delay time	—

POSSIBLE CAUSE

[OPEN]

- Connection malfunction or open circuit of harness and connector
- Internal malfunction of seat belt buckle switch RH

[VB-SHORT]

- Connection malfunction or short circuit to power supply of harness and connector
- Internal malfunction of seat belt buckle switch RH
- Internal malfunction of air bag diagnosis sensor unit

[GND-SHORT]

- Connection malfunction or short circuit to ground of harness and connector
- Internal malfunction of seat belt buckle switch RH
- Internal malfunction of air bag diagnosis sensor unit

[UNDEFINED]

- Connection malfunction or open circuit of harness and connector
- Internal malfunction of seat belt buckle switch RH
- Internal malfunction of air bag diagnosis sensor unit

FAIL-SAFE

—

DTC CONFIRMATION PROCEDURE (With CONSULT)

B1429 SEAT BELT BUCKLE SWITCH RH

< DTC/CIRCUIT DIAGNOSIS >

1. CHECK SELF DIAGNOSTIC RESULT

1. Turn ignition switch ON.
2. Check for DTC using CONSULT.

Is the DTC detected?

YES (Current DTC)>> Refer to [SRC-109, "Diagnosis Procedure"](#).

YES (Past DTC)>> GO TO 2.

NO >> Inspection End.

2. ERASE SELF DIAGNOSTIC RESULT

Erase the DTC using CONSULT.

Can the DTC be erased?

YES >> Inspection End.

NO >> Refer to [SRC-109, "Diagnosis Procedure"](#).

DTC CONFIRMATION PROCEDURE (Without CONSULT)

1. CHECK SELF DIAGNOSTIC RESULT

1. Turn ignition switch ON.
2. Check the air bag warning lamp status. Refer to [SRC-15, "SRS Operation Check"](#).

NOTE:

SRS will not enter diagnosis mode if no malfunction is detected in user mode.

Is the DTC detected?

YES >> Refer to [SRC-109, "Diagnosis Procedure"](#).

NO >> Inspection End.

Diagnosis Procedure

INFOID:000000012159707

1. HARNESS CONNECTOR

Visually inspect all applicable harness connectors for the following:

- Visible damage to connector or terminal
- Loose terminal
- Poor connection

NOTE:

All harness connectors should be inspected from the air bag diagnosis sensor unit to the end component (including any in-line connectors).

Is the inspection result normal?

YES >> GO TO 2.

- NO >> Perform one of the following repairs:
- Visible damage: Replace the harness.
 - Loose terminal: Secure the terminal.
 - Poor connection: Secure the connection.

2. CONFIRM DTC

1. Reconnect all harness connectors.
2. Turn ignition switch ON.
3. Check for DTC using CONSULT.

Is DTC still current?

YES >> GO TO 3.

NO >> Refer to [GI-41, "Intermittent Incident"](#).

3. WIRING HARNESS

Check the wiring harness for visible damage.

NOTE:

The entire wiring harness should be inspected from the air bag diagnosis sensor unit to the end component (including any in-line connectors).

Is the inspection result normal?

YES >> GO TO 4.

A
B
C
D
E
F
G
I
J
K
L
M
N
O
P

SRC

B1429 SEAT BELT BUCKLE SWITCH RH

< DTC/CIRCUIT DIAGNOSIS >

NO >> Replace the harness.

4.CONFIRM DTC

1. Reconnect all harness connectors.
2. Turn ignition switch ON.
3. Check for DTC using CONSULT.

Is DTC still current?

YES >> GO TO 5.

NO >> Refer to [GI-41. "Intermittent Incident"](#).

5.SEAT BELT BUCKLE SWITCH RH

1. Replace the seat belt buckle switch RH. Refer to [SB-8. "SEAT BELT RETRACTOR : Removal and Installation"](#).
2. Turn ignition switch ON.
3. Check for DTC using CONSULT.

Is DTC still current?

YES >> GO TO 6.

NO >> Clear DTC. Inspection End.

6.AIR BAG DIAGNOSIS SENSOR UNIT

1. Replace the air bag diagnosis sensor unit. Refer to [SR-30. "Removal and Installation"](#).
2. Turn ignition switch ON.
3. Check for DTC using CONSULT.

Is DTC still current?

YES >> GO TO 7.

NO >> Clear DTC. Inspection End.

7.RELATED HARNESS

Replace the related harness.

>> Inspection End.

B1430 SEAT BELT PRE-TENSIONER

< DTC/CIRCUIT DIAGNOSIS >

B1430 SEAT BELT PRE-TENSIONER

DTC Description

INFOID:000000012159708

DTC DETECTION LOGIC

DTC	CONSULT name	DTC detecting condition		
B1430	FRONT PRE-TEN LH CIRCUIT [OPEN]	13	Diagnosis condition	When ignition switch is ON.
			Signal (terminal)	LH seat belt pre-tensioner circuit is open (shoulder belt) (terminal 65 and 66).
			Threshold	—
			Diagnosis delay time	—
	FRONT PRE-TEN LH CIRCUIT [VB-SHORT]	12	Diagnosis condition	When ignition switch is ON.
			Signal (terminal)	LH seat belt pre-tensioner circuit is shorted to a power supply circuit (shoulder belt) (terminal 65 and 66).
			Threshold	—
			Diagnosis delay time	—
	FRONT PRE-TEN LH CIRCUIT [GND-SHORT]	11	Diagnosis condition	When ignition switch is ON.
			Signal (terminal)	LH seat belt pre-tensioner circuit is shorted to ground (shoulder belt) (shoulder belt) (terminal 65 and 66).
			Threshold	—
			Diagnosis delay time	—
	FRONT PRE-TEN LH CIRCUIT [SHORT]	09	Diagnosis condition	When ignition switch is ON.
			Signal (terminal)	LH seat belt pre-tensioner circuits are shorted to each other (shoulder belt) (terminal 65 and 66).
			Threshold	—
			Diagnosis delay time	—

POSSIBLE CAUSE

[OPEN]

- Connection malfunction or open circuit of harness and connector
- Internal malfunction of seat belt pre-tensioner LH
- Internal malfunction of air bag diagnosis sensor unit

[VB-SHORT]

- Connection malfunction or short circuit to power supply of harness and connector
- Internal malfunction of seat belt pre-tensioner LH
- Internal malfunction of air bag diagnosis sensor unit

[GND-SHORT]

- Connection malfunction or short circuit to ground of harness and connector
- Internal malfunction of seat belt pre-tensioner LH
- Internal malfunction of air bag diagnosis sensor unit

[SHORT]

- Connection malfunction or short circuit of harness and connector
- Internal malfunction of seat belt pre-tensioner LH
- Internal malfunction of air bag diagnosis sensor unit

FAIL-SAFE

—

B1430 SEAT BELT PRE-TENSIONER

< DTC/CIRCUIT DIAGNOSIS >

DTC CONFIRMATION PROCEDURE (With CONSULT)

1. CHECK SELF DIAGNOSTIC RESULT

Ⓟ CONSULT

1. Turn ignition switch ON.
2. Check DTC.

Is the DTC detected?

YES (Current DTC)>> Refer to [SRC-112, "Diagnosis Procedure"](#).

YES (Past DTC)>> GO TO 2.

NO >> Inspection End.

2. ERASE SELF DIAGNOSTIC RESULT

Ⓟ CONSULT

Erase DTC.

Can the DTC be erased?

YES >> Inspection End.

NO >> Refer to [SRC-112, "Diagnosis Procedure"](#).

DTC CONFIRMATION PROCEDURE (Without CONSULT)

1. CHECK SELF DIAGNOSTIC RESULT

1. Turn ignition switch ON.
2. Check the air bag warning lamp status. Refer to [SRC-15, "SRS Operation Check"](#).

NOTE:

SRS will not enter diagnosis mode if no malfunction is detected in user mode.

Is the DTC detected?

YES >> Refer to [SRC-112, "Diagnosis Procedure"](#).

NO >> Inspection End.

Diagnosis Procedure

INFOID:000000012159709

1. HARNESS CONNECTOR

Visually inspect all applicable harness connectors for the following:

- Visible damage to connector or terminal
- Loose terminal
- Poor connection

NOTE:

All harness connectors should be inspected from the air bag diagnosis sensor unit to the end component (including any in-line connectors).

Is the inspection result normal?

YES >> GO TO 2.

NO >> Perform one of the following repairs:

- Visible damage: Replace the harness.
- Loose terminal: Secure the terminal.
- Poor connection: Secure the connection.

2. CONFIRM DTC

Ⓟ CONSULT

1. Reconnect all harness connectors.
2. Turn ignition switch ON.
3. Check DTC.

Is DTC still current?

YES >> GO TO 3.

NO >> Refer to [GI-41, "Intermittent Incident"](#).

3. WIRING HARNESS

Check the wiring harness for visible damage.

NOTE:

B1430 SEAT BELT PRE-TENSIONER

< DTC/CIRCUIT DIAGNOSIS >

The entire wiring harness should be inspected from the air bag diagnosis sensor unit to the end component (including any in-line connectors).

Is the inspection result normal?

YES >> GO TO 4.

NO >> Replace the harness.

4.CONFIRM DTC

Ⓜ CONSULT

1. Reconnect all harness connectors.
2. Turn ignition switch ON.
3. Check DTC.

Is DTC still current?

YES >> GO TO 5.

NO >> Refer to [GI-41, "Intermittent Incident"](#).

5.AIR BAG DIAGNOSIS SENSOR UNIT

Ⓜ CONSULT

1. Replace the air bag diagnosis sensor unit. Refer to [SR-30, "Removal and Installation"](#).
2. Turn ignition switch ON.
3. Check DTC.

Is DTC still current?

YES >> GO TO 6.

NO >> Clear DTC. Inspection End.

6.SEAT BELT PRE-TENSIONER LH

Ⓜ CONSULT

1. Replace the seat belt pre-tensioner LH. Refer to [SB-8, "SEAT BELT RETRACTOR : Removal and Installation"](#).
2. Turn ignition switch ON.
3. Check DTC.

Is DTC still current?

YES >> GO TO 7.

NO >> Clear DTC. Inspection End.

7.RELATED HARNESS

Replace the related harness.

>> Inspection End.

A
B
C
D
E
F
G
I
J
K
L
M
N
O
P

SRC

B1431 SEAT BELT PRE-TENSIONER

< DTC/CIRCUIT DIAGNOSIS >

B1431 SEAT BELT PRE-TENSIONER

DTC Description

INFOID:000000012159710

DTC DETECTION LOGIC

DTC	CONSULT name	DTC detecting condition		
B1431	FRONT PRE-TEN RH [OPEN]	13	Diagnosis condition	When ignition switch is ON.
			Signal (terminal)	RH seat belt pre-tensioner circuit is open (shoulder belt) (terminal 21 and 22).
			Threshold	—
			Diagnosis delay time	—
	FRONT PRE-TEN RH [VB-SHORT]	12	Diagnosis condition	When ignition switch is ON.
			Signal (terminal)	RH seat belt pre-tensioner circuit is shorted to a power supply circuit (shoulder belt) (terminal 21 and 22).
			Threshold	—
			Diagnosis delay time	—
	FRONT PRE-TEN RH [GND-SHORT]	11	Diagnosis condition	When ignition switch is ON.
			Signal (terminal)	RH seat belt pre-tensioner circuit is shorted to ground (shoulder belt) (terminal 21 and 22).
			Threshold	—
			Diagnosis delay time	—
	FRONT PRE-TEN RH [SHORT]	09	Diagnosis condition	When ignition switch is ON.
			Signal (terminal)	RH seat belt pre-tensioner circuits are shorted to each other (shoulder belt) (terminal 21 and 22).
			Threshold	—
			Diagnosis delay time	—

POSSIBLE CAUSE

[OPEN]

- Connection malfunction or open circuit of harness and connector
- Internal malfunction of seat belt pre-tensioner RH
- Internal malfunction of air bag diagnosis sensor unit

[VB-SHORT]

- Connection malfunction or short circuit to power supply of harness and connector
- Internal malfunction of seat belt pre-tensioner RH
- Internal malfunction of air bag diagnosis sensor unit

[GND-SHORT]

- Connection malfunction or short circuit to ground of harness and connector
- Internal malfunction of seat belt pre-tensioner RH
- Internal malfunction of air bag diagnosis sensor unit

[SHORT]

- Connection malfunction or short circuit of harness and connector
- Internal malfunction of seat belt pre-tensioner RH
- Internal malfunction of air bag diagnosis sensor unit

FAIL-SAFE

B1431 SEAT BELT PRE-TENSIONER

< DTC/CIRCUIT DIAGNOSIS >

DTC CONFIRMATION PROCEDURE (With CONSULT) A

1. CHECK SELF DIAGNOSTIC RESULT

CONSULT B

1. Turn ignition switch ON.
2. Check DTC.

Is the DTC detected? C

YES (Current DTC)>> Refer to [SRC-115, "Diagnosis Procedure"](#).

YES (Past DTC)>> GO TO 2.

NO >> Inspection End. D

2. ERASE SELF DIAGNOSTIC RESULT

CONSULT E

Erase DTC.

Can the DTC be erased? F

YES >> Inspection End.

NO >> Refer to [SRC-115, "Diagnosis Procedure"](#).

DTC CONFIRMATION PROCEDURE (Without CONSULT) G

1. CHECK SELF DIAGNOSTIC RESULT

1. Turn ignition switch ON.
2. Check the air bag warning lamp status. Refer to [SRC-15, "SRS Operation Check"](#).

NOTE:

SRS will not enter diagnosis mode if no malfunction is detected in user mode.

Is the DTC detected? I

YES >> Refer to [SRC-115, "Diagnosis Procedure"](#).

NO >> Inspection End.

Diagnosis Procedure J

INFOID:0000000012159711

1. HARNESS CONNECTOR

Visually inspect all applicable harness connectors for the following: K

- Visible damage to connector or terminal
- Loose terminal
- Poor connection

NOTE:

All harness connectors should be inspected from the air bag diagnosis sensor unit to the end component (including any in-line connectors). L

Is the inspection result normal? M

YES >> GO TO 2.

- NO >> Perform one of the following repairs: N
- Visible damage: Replace the harness.
 - Loose terminal: Secure the terminal.
 - Poor connection: Secure the connection.

2. CONFIRM DTC

CONSULT O

1. Reconnect all harness connectors.
2. Turn ignition switch ON.
3. Check DTC. P

Is DTC still current?

YES >> GO TO 3.

NO >> Refer to [GI-41, "Intermittent Incident"](#).

3. WIRING HARNESS

B1431 SEAT BELT PRE-TENSIONER

< DTC/CIRCUIT DIAGNOSIS >

Check the wiring harness for visible damage.

NOTE:

The entire wiring harness should be inspected from the air bag diagnosis sensor unit to the end component (including any in-line connectors).

Is the inspection result normal?

YES >> GO TO 4.

NO >> Replace the harness.

4. CONFIRM DTC

Ⓟ CONSULT

1. Reconnect all harness connectors.
2. Turn ignition switch ON.
3. Check DTC.

Is DTC still current?

YES >> GO TO 5.

NO >> Refer to [GI-41, "Intermittent Incident"](#).

5. AIR BAG DIAGNOSIS SENSOR UNIT

Ⓟ CONSULT

1. Replace the air bag diagnosis sensor unit. Refer to [SR-30, "Removal and Installation"](#).
2. Turn ignition switch ON.
3. Check DTC.

Is DTC still current?

YES >> GO TO 6.

NO >> Clear DTC. Inspection End.

6. SEAT BELT PRE-TENSIONER RH

Ⓟ CONSULT

1. Replace the seat belt pre-tensioner RH. Refer to [SB-8, "SEAT BELT RETRACTOR : Removal and Installation"](#).
2. Turn ignition switch ON.
3. Check DTC.

Is DTC still current?

YES >> GO TO 7.

NO >> Clear DTC. Inspection End.

7. RELATED HARNESS

Replace the related harness.

>> Inspection End.

B1432 LAP PRE-TENSIONER

< DTC/CIRCUIT DIAGNOSIS >

B1432 LAP PRE-TENSIONER

DTC Logic

INFOID:000000012248912

With CONSULT

DTC	CONSULT name	DTC detecting condition		
B1432	PRE-TEN FRONT RH 2 [OPEN]	13	Diagnosis condition	When ignition switch is ON.
			Signal (terminal)	Front RH seat belt pre-tensioner (lap belt) (Terminal 51 and 52)
			Threshold	—
			Diagnosis delay time	—
	PRE-TEN FRONT RH 2 [VB-SHORT]	12	Diagnosis condition	When ignition switch is ON.
			Signal (terminal)	Front RH seat belt pre-tensioner (lap belt) (Terminal 51 and 52)
			Threshold	—
			Diagnosis delay time	—
	PRE-TEN FRONT RH 2 [GND-SHORT]	11	Diagnosis condition	When ignition switch is ON.
			Signal (terminal)	Front RH seat belt pre-tensioner (lap belt) (Terminal 51 and 52)
			Threshold	—
			Diagnosis delay time	—
	PRE-TEN FRONT RH 2 [SHORT]	1A	Diagnosis condition	When ignition switch is ON.
			Signal (terminal)	Front RH seat belt pre-tensioner (lap belt) (Terminal 51 and 52)
			Threshold	—
			Diagnosis delay time	—
	PRE-TEN FRONT RH 2 [SHORT]	09	Diagnosis condition	When ignition switch is ON.
			Signal (terminal)	Front RH seat belt pre-tensioner (lap belt) (Terminal 51 and 52)
			Threshold	—
			Diagnosis delay time	—

DTC CONFIRMATION PROCEDURE (With CONSULT)

1. CHECK SELF DIAGNOSTIC RESULT

CONSULT

- Turn ignition switch ON.
- Select "Self Diagnostic Result" "AIR BAG"
- Check DTC.

Is the DTC detected?

YES (Current DTC) >> Refer to [SRC-118, "Diagnosis Procedure"](#).

YES (Past DTC) >> GO TO 2.

NO >> Inspection End.

2. ERASE SELF DIAGNOSTIC RESULT

Erase DTC.

Can the DTC be erased?

YES >> Inspection End.

NO >> Refer to [SRC-118, "Diagnosis Procedure"](#).

DTC CONFIRMATION PROCEDURE (Without CONSULT)

B1432 LAP PRE-TENSIONER

< DTC/CIRCUIT DIAGNOSIS >

1. CHECK SELF DIAGNOSTIC RESULT

1. Turn ignition switch ON.
2. Check the air bag warning lamp status. Refer to [SRC-15, "SRS Operation Check"](#).

NOTE:

SRS will not enter diagnosis mode if no malfunction is detected in user mode.

Is the DTC detected?

- YES >> Refer to [SRC-118, "Diagnosis Procedure"](#).
NO >> Inspection End.

Diagnosis Procedure

INFOID:000000012248913

1. HARNESS CONNECTOR

Visually inspect all applicable harness connectors for the following:

- Visible damage to connector or terminal
- Loose terminal
- Poor connection

NOTE:

All harness connectors should be inspected from the air bag diagnosis sensor unit to the end component (including any in-line connectors).

Is the inspection result normal?

- YES >> GO TO 2.
NO >> Perform one of the following repairs:
 - Visible damage: Replace the harness.
 - Loose terminal: Secure the terminal.
 - Poor connection: Secure the connection.

2. CONFIRM DTC

Ⓟ CONSULT

1. Reconnect all harness connectors.
2. Turn ignition switch ON.
3. Check DTC.

Is DTC still current?

- YES >> GO TO 3.
NO >> Refer to [GI-41, "Intermittent Incident"](#).

3. WIRING HARNESS

Check the wiring harness for visible damage.

NOTE:

The entire wiring harness should be inspected from the air bag diagnosis sensor unit to the end component (including any in-line connectors).

Is the inspection result normal?

- YES >> GO TO 4.
NO >> Replace the harness.

4. CONFIRM DTC

Ⓟ CONSULT

1. Reconnect all harness connectors.
2. Turn ignition switch ON.
3. Check DTC.

Is DTC still current?

- YES >> GO TO 5.
NO >> Refer to [GI-41, "Intermittent Incident"](#).

5. AIR BAG DIAGNOSIS SENSOR UNIT

Ⓟ CONSULT

1. Replace the air bag diagnosis sensor unit. Refer to [SR-30, "Removal and Installation"](#).
2. Turn ignition switch ON.

B1432 LAP PRE-TENSIONER

< DTC/CIRCUIT DIAGNOSIS >

3. Check DTC.

Is DTC still current?

YES >> GO TO 6.

NO >> Clear DTC. Inspection End.

6.LAP PRE-TENSIONER LH

Ⓜ CONSULT

1. Replace the lap pre-tensioner LH. Refer to [SB-8, "SEAT BELT RETRACTOR : Removal and Installation"](#).

2. Turn ignition switch ON.

3. Check DTC.

Is DTC still current?

YES >> GO TO 7.

NO >> Clear DTC. Inspection End.

7.RELATED HARNESS

Replace the related harness.

>> Inspection End.

A

B

C

D

E

F

G

SRC

I

J

K

L

M

N

O

P

B1433 LAP PRE-TENSIONER

< DTC/CIRCUIT DIAGNOSIS >

B1433 LAP PRE-TENSIONER

DTC Description

INFOID:000000012159712

DTC DETECTION LOGIC

DTC	CONSULT name	DTC detecting condition		
B1433	PRE-TEN FRONT RH 2 [OPEN]	13	Diagnosis condition	When ignition switch is ON.
			Signal (terminal)	Front RH seat belt pre-tensioner (lap belt) (Terminal 1 and 2)
			Threshold	—
			Diagnosis delay time	—
	PRE-TEN FRONT RH 2 [VB-SHORT]	12	Diagnosis condition	When ignition switch is ON.
			Signal (terminal)	Front RH seat belt pre-tensioner (lap belt) (Terminal 1 and 2)
			Threshold	—
			Diagnosis delay time	—
	PRE-TEN FRONT RH 2 [GND-SHORT]	11	Diagnosis condition	When ignition switch is ON.
			Signal (terminal)	Front RH seat belt pre-tensioner (lap belt) (Terminal 1 and 2)
			Threshold	—
			Diagnosis delay time	—
	PRE-TEN FRONT RH 2 [SHORT]	1A	Diagnosis condition	When ignition switch is ON.
			Signal (terminal)	Front RH seat belt pre-tensioner (lap belt) (Terminal 1 and 2)
			Threshold	—
			Diagnosis delay time	—

POSSIBLE CAUSE

[OPEN]

- Connection malfunction or open circuit of harness and connector
- Internal malfunction of lap belt pre-tensioner RH
- Internal malfunction of air bag diagnosis sensor unit

[VB-SHORT]

- Connection malfunction or short circuit to power supply of harness and connector
- Internal malfunction of lap belt pre-tensioner RH
- Internal malfunction of air bag diagnosis sensor unit

[GND-SHORT]

- Connection malfunction or short circuit to ground of harness and connector
- Internal malfunction of lap belt pre-tensioner RH
- Internal malfunction of air bag diagnosis sensor unit

[SHORT]

- Connection malfunction or short circuit of harness and connector
- Internal malfunction of lap belt pre-tensioner RH
- Internal malfunction of air bag diagnosis sensor unit

FAIL-SAFE

—

DTC CONFIRMATION PROCEDURE (With CONSULT)

B1433 LAP PRE-TENSIONER

< DTC/CIRCUIT DIAGNOSIS >

1.CHECK SELF DIAGNOSTIC RESULT

CONSULT

1. Turn ignition switch ON.
2. Check DTC.

Is the DTC detected?

YES (Current DTC)>> Refer to [SRC-121, "Diagnosis Procedure"](#).

YES (Past DTC)>> GO TO 2.

NO >> Inspection End.

2.ERASE SELF DIAGNOSTIC RESULT

CONSULT

Erase DTC.

Can the DTC be erased?

YES >> Inspection End.

NO >> Refer to [SRC-121, "Diagnosis Procedure"](#).

DTC CONFIRMATION PROCEDURE (Without CONSULT)

1.CHECK SELF DIAGNOSTIC RESULT

1. Turn ignition switch ON.
2. Check the air bag warning lamp status. Refer to [SRC-15, "SRS Operation Check"](#).

NOTE:

SRS will not enter diagnosis mode if no malfunction is detected in user mode.

Is the DTC detected?

YES >> Refer to [SRC-121, "Diagnosis Procedure"](#).

NO >> Inspection End.

Diagnosis Procedure

INFOID:000000012159713

1.HARNES CONNECTOR

Visually inspect all applicable harness connectors for the following:

- Visible damage to connector or terminal
- Loose terminal
- Poor connection

NOTE:

All harness connectors should be inspected from the air bag diagnosis sensor unit to the end component (including any in-line connectors).

Is the inspection result normal?

YES >> GO TO 2.

NO >> Perform one of the following repairs:

- Visible damage: Replace the harness.
- Loose terminal: Secure the terminal.
- Poor connection: Secure the connection.

2.CONFIRM DTC

CONSULT

1. Reconnect all harness connectors.
2. Turn ignition switch ON.
3. Check DTC.

Is DTC still current?

YES >> GO TO 3.

NO >> Refer to [GI-41, "Intermittent Incident"](#).

3.WIRING HARNESS

Check the wiring harness for visible damage.

NOTE:

A
B
C
D
E
F
G
I
J
K
L
M
N
O
P

SRC

B1433 LAP PRE-TENSIONER

< DTC/CIRCUIT DIAGNOSIS >

The entire wiring harness should be inspected from the air bag diagnosis sensor unit to the end component (including any in-line connectors).

Is the inspection result normal?

YES >> GO TO 4.

NO >> Replace the harness.

4.CONFIRM DTC

Ⓟ CONSULT

1. Reconnect all harness connectors.
2. Turn ignition switch ON.
3. Check DTC.

Is DTC still current?

YES >> GO TO 5.

NO >> Refer to [GI-41, "Intermittent Incident"](#).

5.AIR BAG DIAGNOSIS SENSOR UNIT

Ⓟ CONSULT

1. Replace the air bag diagnosis sensor unit. Refer to [SR-30, "Removal and Installation"](#).
2. Turn ignition switch ON.
3. Check DTC.

Is DTC still current?

YES >> GO TO 6.

NO >> Clear DTC. Inspection End.

6.LAP PRE-TENSIONER RH

Ⓟ CONSULT

1. Replace the lap pre-tensioner RH. Refer to [SB-8, "SEAT BELT RETRACTOR : Removal and Installation"](#).
2. Turn ignition switch ON.
3. Check DTC.

Is DTC still current?

YES >> GO TO 7.

NO >> Clear DTC. Inspection End.

7.RELATED HARNESS

Replace the related harness.

>> Inspection End.

B1436 ACTIVE VENT

< DTC/CIRCUIT DIAGNOSIS >

B1436 ACTIVE VENT

DTC Description

INFOID:000000012159716

DTC DETECTION LOGIC

DTC	CONSULT name	DTC detecting condition		
B1436	ACTIVE VENT [OPEN]	13	Diagnosis condition	When ignition switch is ON.
			Signal (terminal)	Active vent circuit (Terminal 43 and 33)
			Threshold	—
			Diagnosis delay time	—
	ACTIVE VENT [VB-SHORT]	12	Diagnosis condition	When ignition switch is ON.
			Signal (terminal)	Active vent circuit (Terminal 43 and 33)
			Threshold	—
			Diagnosis delay time	—
	ACTIVE VENT [GND-SHORT]	11	Diagnosis condition	When ignition switch is ON.
			Signal (terminal)	Active vent circuit (Terminal 43 and 33)
			Threshold	—
			Diagnosis delay time	—
ACTIVE VENT [SHORT]	09	Diagnosis condition	When ignition switch is ON.	
		Signal (terminal)	Active vent circuit (Terminal 43 and 33)	
		Threshold	—	
		Diagnosis delay time	—	

POSSIBLE CAUSE

[OPEN]

- Connection malfunction or open circuit of harness and connector
- Internal malfunction of passenger air bag module (active vent)
- Internal malfunction of air bag diagnosis sensor unit

[VB-SHORT]

- Connection malfunction or short circuit to power supply of harness and connector
- Internal malfunction of passenger air bag module (active vent)
- Internal malfunction of air bag diagnosis sensor unit

[GND-SHORT]

- Connection malfunction or short circuit to ground of harness and connector
- Internal malfunction of passenger air bag module (active vent)
- Internal malfunction of air bag diagnosis sensor unit

[SHORT]

- Connection malfunction or short circuit of harness and connector
- Internal malfunction of passenger air bag module (active vent)
- Internal malfunction of air bag diagnosis sensor unit

FAIL-SAFE

—

DTC CONFIRMATION PROCEDURE (With CONSULT)

B1436 ACTIVE VENT

< DTC/CIRCUIT DIAGNOSIS >

1. CHECK SELF DIAGNOSTIC RESULT

CONSULT

1. Turn ignition switch ON.
2. Check DTC.

Is the DTC detected?

YES (Current DTC)>> Refer to [SRC-124, "Diagnosis Procedure"](#).

YES (Past DTC)>> GO TO 2.

NO >> Inspection End.

2. ERASE SELF DIAGNOSTIC RESULT

CONSULT

Erase DTC.

Can the DTC be erased?

YES >> Inspection End.

NO >> Refer to [SRC-124, "Diagnosis Procedure"](#).

DTC CONFIRMATION PROCEDURE (Without CONSULT)

1. CHECK SELF DIAGNOSTIC RESULT

1. Turn ignition switch ON.
2. Check the air bag warning lamp status. Refer to [SRC-15, "SRS Operation Check"](#).

NOTE:

SRS will not enter diagnosis mode if no malfunction is detected in user mode.

Is the DTC detected?

YES >> Refer to [SRC-124, "Diagnosis Procedure"](#).

NO >> Inspection End.

Diagnosis Procedure

INFOID:0000000012159717

1. HARNESS CONNECTOR

Visually inspect all applicable harness connectors for the following:

- Visible damage to connector or terminal
- Loose terminal
- Poor connection

NOTE:

All harness connectors should be inspected from the air bag diagnosis sensor unit to the end component (including any in-line connectors).

Is the inspection result normal?

YES >> GO TO 2.

- NO >> Perform one of the following repairs:
- Visible damage: Replace the harness.
 - Loose terminal: Secure the terminal.
 - Poor connection: Secure the connection.

2. CONFIRM DTC

CONSULT

1. Reconnect all harness connectors.
2. Turn ignition switch ON.
3. Check DTC.

Is DTC still current?

YES >> GO TO 3.

NO >> Refer to [GI-41, "Intermittent Incident"](#).

3. WIRING HARNESS

Check the wiring harness for visible damage.

NOTE:

B1436 ACTIVE VENT

< DTC/CIRCUIT DIAGNOSIS >

The entire wiring harness should be inspected from the air bag diagnosis sensor unit to the end component (including any in-line connectors).

Is the inspection result normal?

YES >> GO TO 4.

NO >> Replace the harness.

4.CONFIRM DTC

Ⓜ CONSULT

1. Reconnect all harness connectors.
2. Turn ignition switch ON.
3. Check DTC.

Is DTC still current?

YES >> GO TO 5.

NO >> Refer to [GI-41, "Intermittent Incident"](#).

5.AIR BAG DIAGNOSIS SENSOR UNIT

Ⓜ CONSULT

1. Replace the air bag diagnosis sensor unit. Refer to [SR-30, "Removal and Installation"](#).
2. Turn ignition switch ON.
3. Check DTC.

Is DTC still current?

YES >> GO TO 6.

NO >> Clear DTC. Inspection End.

6.FRONT PASSENGER AIR BAG MODULE

Ⓜ CONSULT

1. Replace the front passenger air bag module. Refer to [SR-19, "Removal and Installation"](#).
2. Turn ignition switch ON.
3. Check DTC.

Is DTC still current?

YES >> GO TO 7.

NO >> Clear DTC. Inspection End.

7.RELATED HARNESS

Replace the related harness.

>> Inspection End.

A
B
C
D
E
F
G
I
J
K
L
M
N
O
P

SRC

B142A IGNITION VOLTAGE

< DTC/CIRCUIT DIAGNOSIS >

B142A IGNITION VOLTAGE

DTC Description

INFOID:000000012159718

DTC DETECTION LOGIC

DTC	CONSULT name	DTC detecting condition		
B142A	IGN VOLTAGE [VB-LOW]	00	Diagnosis condition	When ignition switch is ON.
			Signal (terminal)	Ignition voltage low at air bag diagnosis sensor unit.
			Threshold	—
			Diagnosis delay time	—
	IGN VOLTAGE [VB-HIGH]	00	Diagnosis condition	When ignition switch is ON.
			Signal (terminal)	Ignition voltage high at air bag diagnosis sensor unit.
			Threshold	—
			Diagnosis delay time	—

POSSIBLE CAUSE

[VB-LOW]

- Malfunction of battery voltage (low voltage)
- Connection malfunction of harness or connector
- Internal malfunction of air bag diagnosis sensor unit

[VB-HIGH]

- Malfunction of battery voltage (high voltage)
- Connection malfunction of harness or connector
- Internal malfunction of air bag diagnosis sensor unit

FAIL-SAFE

—

DTC CONFIRMATION PROCEDURE (With CONSULT)

1. CHECK SELF DIAGNOSTIC RESULT

Ⓜ CONSULT

1. Turn ignition switch ON.
2. Check DTC.

Is the DTC detected?

YES (Current DTC)>> Refer to [SRC-127, "Diagnosis Procedure"](#).

YES (Past DTC)>> GO TO 2.

NO >> Inspection End.

2. ERASE SELF DIAGNOSTIC RESULT

Ⓜ CONSULT

Erase DTC.

Can the DTC be erased?

YES >> Inspection End.

NO >> Refer to [SRC-127, "Diagnosis Procedure"](#).

DTC CONFIRMATION PROCEDURE (Without CONSULT)

1. CHECK SELF DIAGNOSTIC RESULT

B142A IGNITION VOLTAGE

< DTC/CIRCUIT DIAGNOSIS >

1. Turn ignition switch ON.
2. Check the air bag warning lamp status. Refer to [SRC-15, "SRS Operation Check"](#).

NOTE:

SRS will not enter diagnosis mode if no malfunction is detected in user mode.

Is the DTC detected?

- YES >> Refer to [SRC-127, "Diagnosis Procedure"](#).
NO >> Inspection End.

Diagnosis Procedure

INFOID:000000012159719

1. HARNESS CONNECTOR

Visually inspect all applicable harness connectors for the following:

- Visible damage to connector or terminal
- Loose terminal
- Poor connection

NOTE:

All harness connectors should be inspected from the air bag diagnosis sensor unit to the end component (including any in-line connectors).

Is the inspection result normal?

- YES >> GO TO 2.
NO >> Perform one of the following repairs:
 - Visible damage: Replace the harness.
 - Loose terminal: Secure the terminal.
 - Poor connection: Secure the connection.

2. CONFIRM DTC

CONSULT

1. Reconnect all harness connectors.
2. Turn ignition switch ON.
3. Check DTC.

Is DTC still current?

- YES >> GO TO 3.
NO >> Refer to [GI-41, "Intermittent Incident"](#).

3. WIRING HARNESS

Check the wiring harness for visible damage.

NOTE:

The entire wiring harness should be inspected from the air bag diagnosis sensor unit to the end component (including any in-line connectors).

Is the inspection result normal?

- YES >> GO TO 4.
NO >> Replace the harness.

4. CONFIRM DTC

CONSULT

1. Reconnect all harness connectors.
2. Turn ignition switch ON.
3. Check DTC.

Is DTC still current?

- YES >> GO TO 5.
NO >> Refer to [GI-41, "Intermittent Incident"](#).

5. AIR BAG DIAGNOSIS SENSOR UNIT

CONSULT

1. Replace the air bag diagnosis sensor unit. Refer to [SR-30, "Removal and Installation"](#).
2. Turn ignition switch ON.
3. Check DTC.

Is DTC still current?

B142A IGNITION VOLTAGE

< DTC/CIRCUIT DIAGNOSIS >

YES >> GO TO 6.

NO >> Clear DTC. Inspection End.

6.RELATED HARNESS

Replace the related harness.

>> Inspection End.

B1427 CONFIG SETTING

< DTC/CIRCUIT DIAGNOSIS >

B1427 CONFIG SETTING

DTC Description

INFOID:000000012159720

DTC DETECTION LOGIC

DTC	CONSULT name		DTC detecting condition	
B1427	ECU SETTING (Configuration setting)	55	Diagnosis condition	When ignition switch is ON.
			Signal (terminal)	—
			Threshold	—
			Diagnosis delay time	—

POSSIBLE CAUSE

When air bag diagnosis unit is replaced.

FAIL-SAFE

—

Diagnosis Procedure

INFOID:000000012159721

1.PERFORM CONFIGURATION

Perform configuration for air bag diagnosis sensor unit.

>> Refer to [SRC-39, "CONFIGURATION : Work Procedure"](#).

A
B
C
D
E
F
G
I
J
K
L
M
N
O
P

SRC

B1400, B1401, B1402, B1403, B1404, B1405 AIR BAG DIAGNOSIS SENSOR UNIT

< DTC/CIRCUIT DIAGNOSIS >

B1400, B1401, B1402, B1403, B1404, B1405 AIR BAG DIAGNOSIS SENSOR UNIT

DTC Description

INFOID:000000012159722

DTC DETECTION LOGIC

DTC	CONSULT name	DTC detecting condition		
B1400	CONTROL UNIT [UNIT MALFUNC]	00	Diagnosis condition	When ignition switch is ON.
			Signal (terminal)	—
			Threshold	—
			Diagnosis delay time	—
B1401	CONTROL UNIT [UNIT MALFUNC]	00	Diagnosis condition	When ignition switch is ON.
			Signal (terminal)	—
			Threshold	—
			Diagnosis delay time	—
B1402	CONTROL UNIT [UNIT MALFUNC]	00	Diagnosis condition	When ignition switch is ON.
			Signal (terminal)	—
			Threshold	—
			Diagnosis delay time	—
B1403	CONTROL UNIT [UNIT MALFUNC]	00	Diagnosis condition	When ignition switch is ON.
			Signal (terminal)	—
			Threshold	—
			Diagnosis delay time	—
B1404	CONTROL UNIT [UNIT MALFUNC]	00	Diagnosis condition	When ignition switch is ON.
			Signal (terminal)	—
			Threshold	—
			Diagnosis delay time	—
B1405	CONTROL UNIT [UNIT MALFUNC]	00	Diagnosis condition	When ignition switch is ON.
			Signal (terminal)	—
			Threshold	—
			Diagnosis delay time	—

POSSIBLE CAUSE

Malfunction in air bag diagnosis sensor unit

FAIL-SAFE

—

DTC CONFIRMATION PROCEDURE

1. CHECK SELF DIAGNOSTIC RESULT

CONSULT

1. Turn ignition switch ON.
2. Select "Self Diagnostic Result" mode of "AIR BAG".

CONSULT

1. Turn ignition switch ON.
2. Check the air bag warning lamp status. Refer to [SRC-15, "SRS Operation Check"](#).

NOTE:

SRS does not enter the diagnosis mode if no malfunction is detected in the user mode.

Is malfunctioning part detected?

B1400, B1401, B1402, B1403, B1404, B1405 AIR BAG DIAGNOSIS SENSOR UNIT

< DTC/CIRCUIT DIAGNOSIS >

- YES >> Refer to [SRC-131, "Diagnosis Procedure"](#).
NO-1 >> To check malfunction symptom before repair: Refer to [GI-41, "Intermittent Incident"](#).
NO-2 >> Confirmation after repair: Inspection End.

Diagnosis Procedure

INFOID:0000000012159723

WARNING:

- Before servicing, turn ignition switch OFF, disconnect battery negative terminal, and wait at least 3 minutes or more (to discharge backup capacitor).
- Never use an unspecified tester or other measuring device.

1. CHECK HARNESS CONNECTOR

Check the harness connector for disconnection, looseness or damage.

Is the inspection result normal?

- YES >> GO TO 2.
NO-1 >> Damage: Replace malfunctioning harness and connector.
NO-2 >> Disconnection or looseness: Securely lock the connector.

2. CHECK WIRING HARNESS

Check the wiring harness externals.

Is the inspection result normal?

- YES >> GO TO 3.
NO >> Replace malfunctioning harness and connector.

3. REPLACE AIR BAG DIAGNOSIS SENSOR UNIT

1. Replace air bag diagnosis sensor unit. Refer to [SR-30, "Removal and Installation"](#).
2. Perform DTC confirmation procedure. Refer to [SRC-130, "DTC Description"](#).

Is DTC detected?

- YES >> GO TO 1.
NO >> Inspection End.

A
B
C
D
E
F
G
I
J
K
L
M
N
O
P

SRC

B1406, B1407, B1408, B1409, B1410 AIR BAG DIAGNOSIS SENSOR UNIT

< DTC/CIRCUIT DIAGNOSIS >

B1406, B1407, B1408, B1409, B1410 AIR BAG DIAGNOSIS SENSOR UNIT

DTC Description

INFOID:000000012159724

DTC DETECTION LOGIC

DTC	CONSULT screen items (Trouble diagnosis content)	DTC detecting condition		
B1406	CONTROL UNIT [UNIT MALFUNC]	00	Diagnosis condition	When ignition switch is ON.
			Signal (terminal)	—
			Threshold	—
			Diagnosis delay time	—
B1407	CONTROL UNIT [UNIT MALFUNC]	00	Diagnosis condition	When ignition switch is ON.
			Signal (terminal)	—
			Threshold	—
			Diagnosis delay time	—
B1408	CONTROL UNIT [UNIT MALFUNC]	00	Diagnosis condition	When ignition switch is ON.
			Signal (terminal)	—
			Threshold	—
			Diagnosis delay time	—
B1409	CONTROL UNIT [UNIT MALFUNC]	00	Diagnosis condition	When ignition switch is ON.
			Signal (terminal)	—
			Threshold	—
			Diagnosis delay time	—
B1410	CONTROL UNIT [UNIT MALFUNC]	00	Diagnosis condition	When ignition switch is ON.
			Signal (terminal)	—
			Threshold	—
			Diagnosis delay time	—

POSSIBLE CAUSE

Malfunction in air bag diagnosis sensor unit

FAIL-SAFE

—

DTC CONFIRMATION PROCEDURE

1. CHECK SELF DIAGNOSIS RESULT

CONSULT

1. Turn ignition switch ON.
2. Select "Self Diagnostic Result" mode of "AIR BAG".

CONSULT

1. Turn ignition switch ON.
2. Check the air bag warning lamp status. Refer to [SRC-15, "SRS Operation Check"](#).

NOTE:

SRS does not enter the diagnosis mode if no malfunction is detected in the user mode.

Is malfunctioning part detected?

- YES >> Refer to [SRC-133, "Diagnosis Procedure"](#).
 NO-1 >> To check malfunction symptom before repair: Refer to [GI-41, "Intermittent Incident"](#).
 NO-2 >> Confirmation after repair: Inspection End.

B1406, B1407, B1408, B1409, B1410 AIR BAG DIAGNOSIS SENSOR UNIT

< DTC/CIRCUIT DIAGNOSIS >

Diagnosis Procedure

INFOID:000000012159725

WARNING:

- Before servicing, turn ignition switch OFF, disconnect battery negative terminal, and wait at least 3 minutes or more (to discharge backup capacitor).
- Never use an unspecified tester or other measuring device.

1. CHECK HARNESS CONNECTOR

Check the harness connector for disconnection, looseness or damage.

Is the inspection result normal?

YES >> GO TO 2.

NO-1 >> Damage: Replace malfunctioning harness and connector.

NO-2 >> Disconnection or looseness: Securely lock the connector.

2. CHECK WIRING HARNESS

Check the wiring harness externals.

Is the inspection result normal?

YES >> GO TO 3.

NO >> Replace malfunctioning harness and connector.

3. REPLACE AIR BAG DIAGNOSIS SENSOR UNIT

1. Replace air bag diagnosis sensor unit. Refer to [SR-30, "Removal and Installation"](#).

2. Perform DTC confirmation procedure. Refer to [SRC-132, "DTC Description"](#).

Is DTC detected?

YES >> GO TO 1.

NO >> Inspection End.

A
B
C
D
E
F
G
I
J
K
L
M
N
O
P

SRC

B1411, B1412, B1413, B1414, B1415 AIR BAG DIAGNOSIS SENSOR UNIT

< DTC/CIRCUIT DIAGNOSIS >

B1411, B1412, B1413, B1414, B1415 AIR BAG DIAGNOSIS SENSOR UNIT

DTC Description

INFOID:000000012159726

DTC DETECTION LOGIC

DTC	CONSULT name	DTC detecting condition		
B1411	CONTROL UNIT [UNIT MALFUNC]	00	Diagnosis condition	When ignition switch is ON.
			Signal (terminal)	—
			Threshold	—
			Diagnosis delay time	—
B1412	CONTROL UNIT [UNIT MALFUNC]	00	Diagnosis condition	When ignition switch is ON.
			Signal (terminal)	—
			Threshold	—
			Diagnosis delay time	—
B1413	CONTROL UNIT [UNIT MALFUNC]	00	Diagnosis condition	When ignition switch is ON.
			Signal (terminal)	—
			Threshold	—
			Diagnosis delay time	—
B1414	CONTROL UNIT [UNIT MALFUNC]	00	Diagnosis condition	When ignition switch is ON.
			Signal (terminal)	—
			Threshold	—
			Diagnosis delay time	—
B1415	CONTROL UNIT [UNIT MALFUNC]	00	Diagnosis condition	When ignition switch is ON.
			Signal (terminal)	—
			Threshold	—
			Diagnosis delay time	—

POSSIBLE CAUSE

Malfunction in air bag diagnosis sensor unit

FAIL-SAFE

—

DTC CONFIRMATION PROCEDURE

1. CHECK SELF DIAGNOSTIC RESULT

Ⓟ CONSULT

1. Turn ignition switch ON.
2. Select "Self Diagnostic Result" of "AIR BAG".

Ⓟ CONSULT

1. Turn ignition switch ON.
2. Check the air bag warning lamp status. Refer to [SRC-15. "SRS Operation Check"](#).

NOTE:

SRS does not enter the diagnosis mode if no malfunction is detected in the user mode.

Is malfunctioning part detected?

- YES >> Refer to [SRC-134. "Diagnosis Procedure"](#).
- NO-1 >> To check malfunction symptom before repair: Refer to [GI-41. "Intermittent Incident"](#).
- NO-2 >> Confirmation after repair: Inspection End.

Diagnosis Procedure

INFOID:000000012159727

WARNING:

B1411, B1412, B1413, B1414, B1415 AIR BAG DIAGNOSIS SENSOR UNIT

< DTC/CIRCUIT DIAGNOSIS >

- Before servicing, turn ignition switch OFF, disconnect battery negative terminal, and wait at least 3 minutes or more (to discharge backup capacitor).
- Never use unspecified tester or other measuring device.

1. CHECK HARNESS CONNECTOR

Check the harness connector for disconnection, looseness or damage.

Is the inspection result normal?

YES >> GO TO 2.

NO-1 >> Damage: Replace malfunctioning harness and connector.

NO-2 >> Disconnection or looseness: Securely lock the connector.

2. CHECK WIRING HARNESS

Check the wiring harness externals.

Is the inspection result normal?

YES >> GO TO 3.

NO >> Replace malfunctioning harness and connector.

3. REPLACE AIR BAG DIAGNOSIS SENSOR UNIT

1. Replace air bag diagnosis sensor unit. Refer to [SR-30, "Removal and Installation"](#).

2. Perform DTC confirmation procedure. Refer to [SRC-134, "DTC Description"](#).

Is DTC detected?

YES >> GO TO 1.

NO >> Inspection End.

A
B
C
D
E
F
G
I
J
K
L
M
N
O
P

SRC

B1416, B1417, B1418, B1419, B1420 AIR BAG DIAGNOSIS SENSOR UNIT

< DTC/CIRCUIT DIAGNOSIS >

B1416, B1417, B1418, B1419, B1420 AIR BAG DIAGNOSIS SENSOR UNIT

DTC Description

INFOID:000000012159728

DTC DETECTION LOGIC

DTC	CONSULT screen items (Trouble diagnosis content)	DTC detecting condition		
B1416	CONTROL UNIT [UNIT MALFUNC]	00	Diagnosis condition	When ignition switch is ON.
			Signal (terminal)	Air bag control unit internal trouble, EEPROM
			Threshold	—
			Diagnosis delay time	—
B1417	CONTROL UNIT [UNIT MALFUNC]	00	Diagnosis condition	When ignition switch is ON.
			Signal (terminal)	Air bag control unit internal trouble, Algorithm
			Threshold	—
			Diagnosis delay time	—
B1418	CONTROL UNIT [UNIT MALFUNC]	00	Diagnosis condition	When ignition switch is ON.
			Signal (terminal)	Air bag control unit internal trouble, Configuration
			Threshold	—
			Diagnosis delay time	—
B1419	CONTROL UNIT [UNIT MALFUNC]	00	Diagnosis condition	When ignition switch is ON.
			Signal (terminal)	Air bag control unit internal trouble, other component
			Threshold	—
			Diagnosis delay time	—
B1420	CONTROL UNIT [UNIT MALFUNC]	00	Diagnosis condition	When ignition switch is ON.
			Signal (terminal)	Air bag control unit internal trouble, other component
			Threshold	—
			Diagnosis delay time	—

POSSIBLE CAUSE

Malfunction in air bag diagnosis sensor unit

FAIL-SAFE

—

DTC CONFIRMATION PROCEDURE

1. CHECK SELF DIAGNOSTIC RESULT

CONSULT

1. Turn ignition switch ON.
2. Select "Self Diagnostic Result" mode of "AIR BAG".

CONSULT

1. Turn ignition switch ON.
2. Check the air bag warning lamp status. Refer to [SRC-15. "SRS Operation Check"](#).

NOTE:

SRS does not enter the diagnosis mode if no malfunction is detected in the user mode.

Is malfunctioning part detected?

- YES >> Refer to [SRC-137. "Diagnosis Procedure"](#).
- NO-1 >> To check malfunction symptom before repair: Refer to [GI-41. "Intermittent Incident"](#).
- NO-2 >> Confirmation after repair: Inspection End.

B1416, B1417, B1418, B1419, B1420 AIR BAG DIAGNOSIS SENSOR UNIT

< DTC/CIRCUIT DIAGNOSIS >

Diagnosis Procedure

INFOID:000000012159729

WARNING:

- Before servicing, turn ignition switch OFF, disconnect battery negative terminal, and wait at least 3 minutes or more (to discharge backup capacitor).
- Never use an unspecified tester or other measuring device.

1. CHECK HARNESS CONNECTOR

Check the harness connector for disconnection, looseness or damage.

Is the inspection result normal?

YES >> GO TO 2.

NO-1 >> Damage: Replace malfunctioning harness and connector.

NO-2 >> Disconnection or looseness: Securely lock the connector.

2. CHECK WIRING HARNESS

Check the wiring harness externals.

Is the inspection result normal?

YES >> GO TO 3.

NO >> Replace malfunctioning harness and connector.

3. REPLACE AIR BAG DIAGNOSIS SENSOR UNIT

1. Replace air bag diagnosis sensor unit. Refer to [SR-30, "Removal and Installation"](#).

2. Perform DTC confirmation procedure. Refer to [SRC-136, "DTC Description"](#).

Is DTC detected?

YES >> GO TO 1.

NO >> Inspection End.

A
B
C
D
E
F
G
I
J
K
L
M
N
O
P

SRC

B142X COLLISION DETECTION

< DTC/CIRCUIT DIAGNOSIS >

B142X COLLISION DETECTION

DTC Description

INFOID:000000012159730

DTC DETECTION LOGIC

DTC	CONSULT name	DTC detecting condition		
B1421	FRONTAL COLLISION DETECTION	00	Diagnosis condition	When ignition switch is ON.
			Signal (terminal)	—
			Threshold	—
			Diagnosis delay time	—
B1422	SIDE COLLISION DETECTION	00	Diagnosis condition	When ignition switch is ON.
			Signal (terminal)	—
			Threshold	—
			Diagnosis delay time	—
B1423	ROLLOVER DETECTION	00	Diagnosis condition	When ignition switch is ON.
			Signal (terminal)	—
			Threshold	—
			Diagnosis delay time	—
B1425	REAR COLLISION	00	Diagnosis condition	When ignition switch is ON.
			Signal (terminal)	—
			Threshold	—
			Diagnosis delay time	—

POSSIBLE CAUSE

[B1421-00]

- Malfunction of frontal-related parts
- Internal malfunction of air bag diagnosis sensor unit

[B1422-00]

- Malfunction of side-related parts
- Internal malfunction of air bag diagnosis sensor unit

[B1423-00]

- B1423—Malfunction of side-related parts
- Internal malfunction of air bag diagnosis sensor unit

[B1425-00]

- B1425—Malfunction of rear-related parts
- Internal malfunction of air bag diagnosis sensor unit

FAIL-SAFE

—

DTC CONFIRMATION PROCEDURE (With CONSULT)

1.INSPECTION START

Turn ignition switch ON.

>> GO TO 2.

2.CHECK SELF DIAGNOSTIC RESULT

Check for the DTC on CONSULT.

B142X COLLISION DETECTION

< DTC/CIRCUIT DIAGNOSIS >

Is the DTC detected?

YES >> Refer to [SRC-139, "Diagnosis Procedure"](#).

NO >> Inspection End.

Diagnosis Procedure

INFOID:000000012159731

Refer to [SR-5, "For Frontal Collision"](#) or [SR-7, "For Side and Rollover Collision"](#).

A
B
C
D
E
F
G
I
J
K
L
M
N
O
P

SRC

B14XX AIR BAG DIAGNOSIS SENSOR UNIT

< DTC/CIRCUIT DIAGNOSIS >

B14XX AIR BAG DIAGNOSIS SENSOR UNIT

DTC Description

INFOID:000000012159732

DTC DETECTION LOGIC

DTC	CONSULT name	DTC detecting condition	
B14XX	AIRBAG DISPOSAL COMPLETION	Diagnosis condition	When ignition switch is ON.
		Signal (terminal)	Air bag diagnosis sensor unit is malfunctioning.
		Threshold	—
		Diagnosis delay time	—
B1426	AIRBAG DISPOSAL DETECT	Diagnosis condition	When ignition is ON.
		Signal (terminal)	Air bag diagnosis sensor unit is malfunctioning.
		Threshold	—
		Diagnosis delay time	—

POSSIBLE CAUSE

- Air bag module has been deployed
- Internal malfunction of air bag diagnosis sensor unit

FAIL-SAFE

—

DTC CONFIRMATION PROCEDURE (With CONSULT)

1. CHECK SELF DIAGNOSIS RESULT

Ⓟ CONSULT

1. Turn ignition switch ON.
2. Check DTC.

Is the DTC detected?

- YES (Current DTC)>> Refer to [SRC-141, "Diagnosis Procedure"](#).
- YES (Past DTC)>> GO TO 2.
- NO >> Inspection End.

2. ERASE SELF DIAGNOSIS RESULT

Ⓟ CONSULT

Erase DTC.

Can the DTC be erased?

- YES >> Inspection End.
- NO >> Refer to [SRC-141, "Diagnosis Procedure"](#).

DTC CONFIRMATION PROCEDURE (Without CONSULT)

1. CHECK SELF DIAGNOSIS RESULT

1. Turn ignition switch ON.
2. Check the air bag warning lamp status. Refer to [SRC-15, "SRS Operation Check"](#).

NOTE:

SRS will not enter diagnosis mode if no malfunction is detected in user mode.

Is the DTC detected?

- YES >> Refer to [SRC-141, "Diagnosis Procedure"](#).
- NO >> Inspection End.

B14XX AIR BAG DIAGNOSIS SENSOR UNIT

< DTC/CIRCUIT DIAGNOSIS >

Diagnosis Procedure

INFOID:000000012159733

1. HARNESS CONNECTOR

Visually inspect all applicable harness connectors for the following:

- Visible damage to connector or terminal
- Loose terminal
- Poor connection

NOTE:

All harness connectors should be inspected from the air bag diagnosis sensor unit to the end component (including any in-line connectors).

Is the inspection result normal?

YES >> GO TO 2.

- NO >> Perform one of the following repairs:
- Visible damage: Replace the harness.
 - Loose terminal: Secure the terminal.
 - Poor connection: Secure the connection.

2. CONFIRM DTC

 CONSULT

1. Reconnect all harness connectors.
2. Turn ignition switch ON.
3. Check DTC.

Is DTC still current?

YES >> GO TO 3.

NO >> Refer to [GI-41, "Intermittent Incident"](#).

3. WIRING HARNESS

Check the wiring harness for visible damage.

NOTE:

The entire wiring harness should be inspected from the air bag diagnosis sensor unit to the end component (including any in-line connectors).

Is the inspection result normal?

YES >> GO TO 4.

NO >> Replace the harness.

4. CONFIRM DTC

 CONSULT

1. Reconnect all harness connectors.
2. Turn ignition switch ON.
3. Check DTC.

Is DTC still current?

YES >> GO TO 5.

NO >> Refer to [GI-41, "Intermittent Incident"](#).

5. AIR BAG DIAGNOSIS SENSOR UNIT

 CONSULT

1. Replace the air bag diagnosis sensor unit. Refer to [SR-30, "Removal and Installation"](#).
2. Turn ignition switch ON.
3. Check DTC.

Is DTC still current?

YES >> GO TO 6.

NO >> Clear DTC. Inspection End.

6. RELATED HARNESS

Replace the related harness.

>> Inspection End.

A
B
C
D
E
F
G
I
J
K
L
M
N
O
P

SRC

SRS AIR BAG WARNING LAMP DOES NOT TURN ON

< SYMPTOM DIAGNOSIS >

SYMPTOM DIAGNOSIS

SRS AIR BAG WARNING LAMP DOES NOT TURN ON

Air Bag Warning Lamp Does Not Turn On

INFOID:000000012159734

1. CHECK METER FUSE

Check the 10A fuse [No. 13, located in the fuse block (J/B)].

Is the fuse blown?

YES >> GO TO 2.

NO >> GO TO 3.

2. REPLACE METER FUSE AND CHECK AGAIN

Replace 10A fuse [No. 13, located in the fuse block (J/B)] and turn ignition switch ON.

Does the fuse blow again?

YES >> Replace fuse and harness.

NO >> Inspection End.

3. CHECK HARNESS CONNECTIONS BETWEEN AIR BAG DIAGNOSIS SENSOR UNIT AND COMBINATION METER

Inspect the harness and connectors between the air bag diagnosis sensor unit and the combination meter.

Do the harness or connectors have any visible damage?

YES >> Replace harness.

NO >> GO TO 4.

4. CHECK COMBINATION METER

Disconnect the air bag diagnosis sensor unit harness connectors and turn ignition switch ON.

Does air bag warning lamp turn on?

YES >> Replace the air bag diagnosis sensor unit. Refer to [SR-30. "Removal and Installation"](#).

NO >> Replace the combination meter. Refer to [MWI-68. "Removal and Installation"](#).

SRS AIR BAG WARNING LAMP DOES NOT TURN OFF

< SYMPTOM DIAGNOSIS >

SRS AIR BAG WARNING LAMP DOES NOT TURN OFF

Air Bag Warning Lamp Does Not Turn Off

INFOID:000000012159735

1.CHECK CONDITION OF AIR BAG MODULE

Inspect for any deployed air bag modules or seat belt pre-tensioners.

Are any air bag modules or seat belt pre-tensioners deployed?

- YES >> Refer to [SR-5. "For Frontal Collision"](#) or [SR-7. "For Side and Rollover Collision"](#).
- NO >> GO TO 2.

2.CHECK THE AIR BAG FUSE

Check 10A fuse [No. 32, located in the fuse block (J/B)].

Is the fuse blown?

- YES >> GO TO 3.
- NO >> GO TO 4.

3.CHECK AIR BAG FUSE AGAIN

Replace 10A fuse [No. 32, located in the fuse block (J/B)] and turn ignition switch ON.

Does the fuse blow again?

- YES >> Replace fuse and harness.
- NO >> Inspection End.

4.CHECK AIR BAG DIAGNOSIS SENSOR UNIT

Connect CONSULT.

Is "AIR BAG" displayed on CONSULT?

- YES >> GO TO 5.
- NO >> Visually inspect the air bag diagnosis sensor unit harness connections. If the connections are OK, replace the air bag diagnosis sensor unit. Refer to [SR-30. "Removal and Installation"](#).

5.CHECK HARNESS CONNECTION

Check for loose connections between the combination meter and the air bag diagnosis sensor unit.

Are there any loose connections?

- YES >> Properly connect the combination meter and air bag diagnosis sensor unit harness connectors. If air bag warning lamp still does not turn off, replace the wiring harness.
- NO >> Replace air bag diagnosis sensor unit. Refer to [SR-30. "Removal and Installation"](#).

A
B
C
D
E
F
G
I
J
K
L
M
N
O
P

SRC

SEAT BELT WARNING SYSTEM

< SYMPTOM DIAGNOSIS >

SEAT BELT WARNING SYSTEM

Seat Belt Warning System Does Not Function

INFOID:000000012159736

1. SEAT BELT WARNING LIGHT

Turn ignition switch ON.

Does the seat belt warning lamp come ON?

YES >> GO TO 2.

- NO >> • Check 10A fuse [No. 13, located in the fuse block (J/B)].
- Check seat belt buckle switch LH.
 - Check harness between combination meter and seat belt buckle switch LH.
 - Check combination meter. Refer to [MWI-28, "Fail-safe"](#).

2. SEAT BELT BUCKLE LH

Fasten the seat belt buckle LH.

Does the seat belt warning lamp go OFF?

YES >> GO TO 3.

- NO >> • Check seat belt buckle switch LH.
- Check harness between combination meter and seat belt buckle switch LH.

3. OCCUPANT CLASSIFICATION SYSTEM

Have a helper sit in the passenger seat.

Does the seat belt warning lamp go ON?

YES >> GO TO 4.

- NO >> • Check occupant classification system. Refer to [SRC-12, "OCCUPANT CLASSIFICATION SYSTEM: System Description"](#).
- Check harness between occupant classification control unit and air bag diagnosis sensor unit.

4. SEAT BELT BUCKLE RH

Fasten the seat belt buckle RH.

Does the seat belt warning lamp go OFF?

YES >> System OK.

- NO >> • Check seat belt buckle switch RH.
- Check harness between seat belt buckle switch RH and air bag diagnosis sensor unit.
 - Replace air bag diagnosis sensor unit. Refer to [SR-30, "Removal and Installation"](#).

A/B WARNING LAMP IS OFF, PASS A/B INDCTR LAMP TURNS ON INTERMIT

< SYMPTOM DIAGNOSIS >

A/B WARNING LAMP IS OFF, PASS A/B INDCTR LAMP TURNS ON INTERMIT

Description

INFOID:000000012159737

SRS air bag warning lamp is OFF, passenger air bag indicator lamp turns ON intermittently with a person of adult stature seated normally in the passenger seat.

Diagnosis Procedure

INFOID:000000012159738

1. REPLACE OCS SENSORS

1. Replace the OCS sensors. Refer to [SR-34. "Removal and Installation - Control Unit"](#).
2. Perform zero point reset. Refer to [SRC-39. "ZERO POINT RESET : Description"](#).

Is symptom still present?

YES >> GO TO 2.

NO >> Inspection End.

2. REPLACE PASSENGER SEAT CUSHION FRAME

1. Replace the passenger seat cushion frame. Refer to [SE-108. "PASSENGER SIDE : Seat Cushion"](#).
2. Perform zero point reset. Refer to [SRC-39. "ZERO POINT RESET : Description"](#).

>> Inspection End.

A
B
C
D
E
F
G
I
J
K
L
M
N
O
P

SRC

SEAT BELT INDCTR LAMP IS ON, PASS AIR BAG INDCTR IS ON OR OFF

< SYMPTOM DIAGNOSIS >

SEAT BELT INDCTR LAMP IS ON, PASS AIR BAG INDCTR IS ON OR OFF

Description

INFOID:000000012159739

Vehicle conditions:

- Seat belt indicator lamp is ON, passenger air bag indicator lamp is ON or OFF
- Passenger seat is unoccupied
- Driver seat belt is buckled
- Passenger seat belt buckle harness and seat belt buckle switch are OK (buckle passenger seat belt to check if seat belt indicator lamp turns OFF, driver seat belt needs to be buckled)

Diagnosis Procedure

INFOID:000000012159740

1.REPLACE OCS SENSORS

1. Replace the OCS sensors. Refer to [SR-34, "Removal and Installation - Control Unit"](#).
2. Perform zero point reset. Refer to [SRC-39, "ZERO POINT RESET : Description"](#).

Is symptom still present?

YES >> GO TO 2.

NO >> Inspection End.

2.REPLACE PASSENGER SEAT CUSHION FRAME

1. Replace the passenger seat cushion frame. Refer to [SE-108, "PASSENGER SIDE : Seat Cushion"](#).
2. Perform zero point reset. Refer to [SRC-39, "ZERO POINT RESET : Description"](#).

>> Inspection End.